

Invariants of Legendrian and transverse knots in monopole knot homology

JOHN A. BALDWIN AND STEVEN SIVEK

We use the contact invariant defined in [3] to construct a new invariant of Legendrian knots in Kronheimer and Mrowka’s monopole knot homology theory (KHM), following a prescription of Stipsicz and Vértesi. Our Legendrian invariant improves upon an earlier Legendrian invariant in KHM defined by the second author in several important respects. Most notably, ours is preserved by negative stabilization. This fact enables us to define a transverse knot invariant in KHM via Legendrian approximation. It also makes our invariant a more likely candidate for the monopole Floer analogue of the “LOSS” invariant in knot Floer homology. Like its predecessor, our Legendrian invariant behaves functorially with respect to Lagrangian concordance. We show how this fact can be used to compute our invariant in several examples. As a byproduct of our investigations, we provide the first infinite family of nonreversible Lagrangian concordances between prime knots.

1	Introduction	960
2	Preliminaries	967
3	Invariants of Legendrian and transverse knots	977
4	A map induced by Lagrangian concordances	988
5	Examples and nonreversible Lagrangian concordances	993
	References	997

1. Introduction

A basic goal in contact geometry is to construct invariants that can distinguish Legendrian or transverse knots in a contact 3-manifold which are smoothly isotopic and have the same classical invariants but are not Legendrian or transversely isotopic. Such an invariant is said to be *effective*. Effective Legendrian invariants include Chekanov and Eliashberg’s Legendrian contact homology (*LCH*) [8, 15] and the “LOSS” and “GRID” invariants in knot Floer homology defined by Lisca, Ozsváth, Stipsicz, and Szabó [33] and Ozsváth, Szabó, and Thurston [39], respectively. Effective transverse invariants are harder to come by; the only known examples are those arising from the LOSS and GRID invariants via Legendrian approximation and the transverse knot contact homology theory developed by Ng et al. [12, 35].

In this paper, we define a new invariant of Legendrian knots using Kronheimer and Mrowka’s monopole knot homology theory (*KHM*). This theory is the monopole Floer analogue of knot Floer homology and we expect that our invariant is the corresponding analogue of the LOSS invariant in a sense made precise later. It bears mentioning that ours is the second Legendrian invariant defined in *KHM*; the first was defined by the second author in [43]. However, our construction is substantially different and improves upon this earlier invariant in several important respects. Most notably, our invariant is preserved by negative stabilization and thus gives rise to a new transverse invariant via Legendrian approximation.

Like the second author’s invariant, ours behaves functorially with respect to Lagrangian concordance, something which is not known to be true of the LOSS invariant. If the LOSS invariant *were* functorial in this way, then the equivalence [5] between the LOSS and GRID invariants would provide easily computable obstructions to the existence of Lagrangian concordances between Legendrian knots in the tight contact structure on S^3 . Indeed, in [4] we have used the construction in this paper to prove this functoriality for the LOSS invariant, as explained in more detail at the end of this introduction.

Below, we outline the constructions of our Legendrian and transverse invariants and describe some of their properties, elaborating on several points in the discussion above. We also describe how our investigations led us to an infinite family of nonreversible Lagrangian concordances between prime knots. At the end, we discuss how our work in [4] relates these invariants to the LOSS and GRID invariants.

1.1. The contact invariant in sutured monopole homology

Our Legendrian and transverse invariants are defined in terms of the contact invariant in sutured monopole homology (SHM) constructed in [3]. We therefore recall this construction briefly below.

The *sutured monopole homology* of a balanced sutured manifold (M, Γ) , as defined by Kronheimer and Mrowka in [25], is an isomorphism class of \mathcal{R} -modules, denoted by $\underline{SHM}(M, \Gamma)$, where \mathcal{R} is the Novikov ring with integer coefficients. It is defined in terms of the monopole Floer homology of a *closure* of (M, Γ) , which is a pair (Y, R) , where Y is a certain closed 3-manifold containing M and R is a distinguished surface in Y . In [2], we introduced canonical isomorphisms, well-defined up to multiplication by units in \mathcal{R} , relating the Floer homology groups associated to different closures of (M, Γ) . These Floer groups and isomorphisms make up what we call a *projectively transitive systems of \mathcal{R} -modules*, denoted by $\underline{SHM}(M, \Gamma)$. This is a more subtle invariant of (M, Γ) than the isomorphism class $\underline{SHM}(M, \Gamma)$. In particular, it makes sense to talk about elements of and morphisms between projectively transitive systems, whereas these notions are much less interesting for isomorphism classes of \mathcal{R} -modules.

Suppose ξ is a contact structure on M such that ∂M is convex with dividing set Γ . In [3], we introduced the notion of a *contact closure* of the *sutured contact manifold* (M, Γ, ξ) . Roughly, this is a triple $(Y, R, \bar{\xi})$, where (Y, R) is a closure of (M, Γ) and $\bar{\xi}$ is a certain contact structure on Y extending ξ . For each such contact closure, the contact invariant $\psi(Y, \bar{\xi})$ in the monopole Floer homology of $-Y$, as defined by Kronheimer and Mrowka in [24, 26], determines an element of $\underline{SHM}(-M, -\Gamma)$. We proved that for contact closures of sufficiently high genus (where the *genus* of a closure refers to that of its distinguished surface R), the induced elements of $\underline{SHM}(-M, -\Gamma)$ all agree—that is, they are independent of the closure. Our contact invariant is defined to be this common element, denoted by

$$\psi(M, \Gamma, \xi) \in \underline{SHM}(-M, -\Gamma).$$

1.2. Legendrian and transverse invariants in monopole knot homology

The *monopole knot homology* of a knot K in a closed 3-manifold Y , as defined by Kronheimer and Mrowka in [25], is the isomorphism class of \mathcal{R} -modules

$$\underline{KHM}(Y, K) := \underline{SHM}(Y \setminus \nu(K), m \cup -m),$$

where $\nu(K)$ is a tubular neighborhood of the knot and m is an oriented meridian on the boundary of this knot complement. In [2], we introduced a refinement of this invariant which assigns to a based knot (K, p) in Y a projectively transitive system of \mathcal{R} -modules, denoted by $\mathbf{KHM}(Y, K, p)$, which is similarly defined in terms of the systems $\mathbf{SHM}(Y \setminus \nu(K), m \cup -m)$ associated to the various possible knot complements $(Y \setminus \nu(K), m \cup -m)$.

The Legendrian invariant defined in this paper assigns to a based, oriented Legendrian knot (K, p) in (Y, ξ) an element

$$\mathcal{L}(K) \in \mathbf{KHM}(-Y, K, p).$$

To define this element, we first remove a standard neighborhood of K and then glue on a piece called a *bypass* (roughly, half of a thickened overtwisted disk) in such a way that the result is the complement of a tubular neighborhood of K with dividing set a pair of oppositely oriented meridians. Suppose $(Y \setminus \nu(K), m \cup -m, \xi_K)$ is the sutured contact manifold formed in this way. The Legendrian invariant of K is then defined, very roughly speaking, by

$$\mathcal{L}(K) := \psi(Y \setminus \nu(K), m \cup -m, \xi_K) \in \mathbf{KHM}(-Y, K, p).$$

We prove that, up to isomorphism, this class is preserved by contactomorphism and Legendrian isotopy (see Proposition 3.4 and Corollary 3.5 for more precise statements). In particular, a Legendrian isotopy f_t sending (K, p) to (K', p') gives rise to a well-defined map

$$\Psi_{f_t} : \mathbf{KHM}(-Y, K, p) \rightarrow \mathbf{KHM}(-Y, K', p')$$

sending $\mathcal{L}(K)$ to $\mathcal{L}(K')$. In [37], Ozsváth and Stipsicz used a similar sort of naturality statement about the LOSS invariant (which is true modulo incorporating the results of [23]) to distinguish smoothly isotopic Legendrian knots with the same classical invariants.

Our construction is inspired by work of Stipsicz and Vértesi [45] who proved that the LOSS invariant can be formulated in a similar way in terms of Honda, Kazez, and Matic's contact invariant in sutured (Heegaard) Floer homology [20]. We also use their work to prove that our invariant shares some important features with the LOSS invariant—most notably, that \mathcal{L} is preserved by negative Legendrian stabilization (Theorem 3.7). This fact allows us to define an invariant of based, oriented transverse knots via Legendrian approximation as in [33, 37]. Namely, given a transverse knot $(K, p) \subset (Y, \xi)$, we choose a Legendrian pushoff (K', p') of (K, p) in a standard neighborhood

of K , and define

$$\mathcal{T}(K) := \mathcal{L}(K') \in \underline{\mathbf{KHM}}(-Y, K, p)$$

to be the transverse invariant of K .¹ The fact that any two such Legendrian pushoffs of K are related by negative stabilization and Legendrian isotopy [16] implies that $\mathcal{T}(K)$ is well-defined and is preserved, up to natural isomorphism, by contactomorphism and transverse isotopy (Proposition 3.10 and Corollary 3.11); in particular, transverse isotopies give rise to well-defined maps sending transverse invariant to transverse invariant as discussed above for the Legendrian invariant.

In [4] we prove the following; see Section 1.3 for details.

Theorem 1.1. *\mathcal{L} and \mathcal{T} are effective invariants of Legendrian and transverse knots.*

As mentioned at the beginning of this introduction, ours is the second Legendrian invariant constructed using monopole knot homology. In [43], the second author defined an invariant which associates to a Legendrian knot $K \subset (Y, \xi)$ a sequence of “elements”

$$\ell(K) = \{\ell_g(K) \in \underline{KHM}(-Y, K)\}_{g=2}^{\infty}.$$

Each $\ell_g(K)$ is defined in terms of Kronheimer and Mrowka’s contact invariant for closed contact 3-manifolds, after extending the contact structure on the complement of a standard neighborhood of K to a contact structure on a genus g closure of the knot complement with its meridional sutures. This invariant was also designed as a potential monopole Floer analogue of the LOSS invariant, and is also conjectured to be an effective invariant of Legendrian knots.

As mentioned above, our Legendrian invariant \mathcal{L} improves upon ℓ in a few important respects. First, while our invariant is also fundamentally a sequence $\{\mathcal{L}_g\}$ of elements, one for each genus, we are able to show that all of these \mathcal{L}_g are equal for g large enough, whereas the corresponding statement for the ℓ_g is only conjectured in [43]. Second, the fact that our invariant is defined in terms of our “natural” refinement of monopole knot homology makes it possible in principle to distinguish the invariants associated to two Legendrian representatives of the same based knot type, even when both are nonzero, something that is not possible for nonzero “elements” of an

¹After identifying $\underline{\mathbf{SHM}}(-Y, K', p')$ with $\underline{\mathbf{SHM}}(-Y, K, p)$ in a canonical way.

isomorphism class of \mathcal{R} -modules. Finally, as discussed above, we prove that \mathcal{L} is preserved by negative stabilization and can therefore be used to define a transverse invariant. By contrast, the second author shows in [43] that ℓ is killed by a composition of positive and negative Legendrian stabilizations, but is not able to prove that it is preserved by negative stabilization. In fact, as defined, ℓ is an invariant of *unoriented* Legendrian knots and so *cannot* be used to distinguish between positive and negative stabilization (or to define an transverse invariant).

One of the most interesting features of our Legendrian invariant is that, like ℓ , it is functorial with respect to Lagrangian concordance in the following sense.

Theorem 1.2. *Suppose (K_-, p_-) and (K_+, p_+) are Legendrian knots in (Y, ξ) such that K_- is Lagrangian concordant to K_+ in the symplectization of (Y, ξ) . Then there exists a map*

$$\mathbf{KHM}(-Y, K_+, p_+) \rightarrow \mathbf{KHM}(-Y, K_-, p_-)$$

which sends $\mathcal{L}(K_+)$ to $\mathcal{L}(K_-)$.

We expect this map to be an invariant of the Lagrangian cylinder from K_- to K_+ , perhaps after decorating this cylinder with an arc from p_- to p_+ , but leave this for future work.

Our proof of Theorem 1.2 is modeled on the proof of the analogous result for ℓ : roughly, we remove a standard neighborhood of the Lagrangian concordance in $Y \times \mathbb{R}$ and glue back the symplectization of a certain contact manifold with boundary, so as to form an exact symplectic cobordism between the contact closures used to define $\mathcal{L}(K_{\pm})$. The theorem then follows from the functoriality of Kronheimer and Mrowka's contact invariant for closed contact 3-manifolds under exact symplectic cobordism. It is not known whether Ozsváth and Szabó's contact invariant in Heegaard Floer homology enjoys the same kind of functoriality, which makes proving the analogue of Theorem 1.2 for the LOSS invariant difficult.

Here we also mention another advantage of our invariant $\mathcal{L}(K)$ over the LOSS invariant. The contact class in Heegaard Floer homology (for both closed and sutured 3-manifolds), and by extension the LOSS invariant as well, are defined in terms of open book diagrams, and so their proofs of invariance rely on the Giroux correspondence. In particular, they require the claim that any two open books which support a given contact structure have some common positive stabilization, but a complete proof of this claim has yet to appear in the literature. By contrast, our contact class $\psi(M, \Gamma, \xi)$

in sutured monopole homology makes no use of any of this (see the discussion in the introduction to [3]) and is thus an unambiguously well-defined, natural invariant. Since $\mathcal{L}(K)$ is the contact class associated to a particular contact manifold, it follows that $\mathcal{L}(K)$ is equally well-defined.

In Section 4, we use Theorem 1.2 to prove the nonvanishing of $\mathcal{L}(K)$ for a few examples, including Legendrian representatives of $m(8_{20})$ and $m(11n_{71})$. Our approach is to find another knot K' with nonzero invariant (for example, the $tb = -1$ unknot) and construct a Lagrangian concordance from some negative stabilization of K' to K (stabilizing gives us more flexibility in constructing the concordance). The nonvanishing of $\mathcal{L}(K)$ then follows from properties of \mathcal{L} discussed above.

Legendrian contact homology enjoys a similar functoriality under Lagrangian cobordism [13]. However, one cannot use the above technique to deduce nonvanishing results for LCH in our examples since LCH vanishes for stabilized knots. On the other hand, LCH can be used to show that the concordances we construct are *nonreversible*. The first examples of nonreversible Lagrangian concordances were discovered by Chantraine [6]. In the course of our investigations, we found a new infinite family of nonreversible concordances, from Legendrian unknots to 3-stranded Legendrian pretzel knots. While this discovery does not rely on our Legendrian invariant, it is perhaps of independent interest as it provides the first infinite family of nonreversible Lagrangian concordances between *prime* knots.

1.3. Equivalence of Legendrian invariants

In [4] we prove an equivalence between our Legendrian and transverse knot invariants and the “hat” versions of the LOSS/GRID invariants defined in knot Floer homology, as explained below.

Suppose (M, Γ, ξ) is a sutured contact manifold. The combined work of Kronheimer and Mrowka [25, Lemma 4.9], Taubes [46–50], Colin, Ghiggini, and Honda [9–11], and Lekili [32] shows that

$$(1) \quad \underline{\mathbf{SHM}}(-M, -\Gamma) \cong SFH(-M, -\Gamma) \otimes \mathcal{R}.$$

Specifically, Taubes and Colin–Ghiggini–Honda prove that there is an isomorphism between monopole Floer homology and Heegaard Floer homology (in fact, one which identifies the contact invariants in either homology theory), and Lekili proves that applying Kronheimer–Mrowka’s construction of

\underline{SHM} in Heegaard Floer theory instead (i.e. using their construction with HF^+ in place of HM) yields an invariant which is isomorphic to SFH .²

In [4], we supply an alternative proof of Lekili's result, which again proves the equivalence (1), but the isomorphism coming from our construction can further be shown to identify our contact invariant $\psi(M, \Gamma, \xi)$ with Honda, Kazez, and Matic's contact invariant

$$EH(M, \Gamma, \xi) \otimes 1 \in SFH(-M, -\Gamma) \otimes \mathcal{R}.$$

Now suppose (K, p) is a based, oriented Legendrian knot in (Y, ξ) . A special case of (1) is the following isomorphism between monopole knot homology and knot Floer homology,

$$(2) \quad \underline{KHM}(-Y, K, p) \cong \widehat{HFK}(-Y, K, p) \otimes \mathcal{R}.$$

By our construction of \mathcal{L} , combined with Stipsicz and Vértesi's interpretation of the LOSS invariant, the equivalence of our contact invariant with Honda, Kazez, and Matic's implies that the isomorphism in (2) identifies $\mathcal{L}(K)$ with the LOSS invariant of K .

Such an identification implies that \mathcal{L} and \mathcal{T} are effective, proving Theorem 1.1: it suffices to find a pair of Legendrian knots K_1, K_2 in S^3 with the same smooth knot type and classical invariants for which the LOSS invariant of K_1 vanishes while that of K_2 is nonzero, and for this we can consider the pair of Legendrian $m(10_{132})$ knots of [36, Theorem 1.1]. It also establishes a functoriality result for the LOSS invariant with respect to Lagrangian concordance, analogous to Theorem 1.2. As explained above, this functoriality, combined with the equivalence of the GRID and LOSS invariants for Legendrian knots in the standard tight S^3 , provides easily computable obstructions to the existence of Lagrangian concordances between such knots.

1.4. Organization

In Section 2, we review projectively transitive systems, the constructions of sutured monopole homology, monopole knot homology, and our contact invariant in SHM . In Section 3, we define the Legendrian and transverse knot invariants \mathcal{L} and \mathcal{T} and establish some of their basic properties. In Section 4, we prove that our Legendrian invariant is functorial with respect to Lagrangian concordance. In Section 5, we illustrate how this functoriality

²One can think of $SFH(-M, -\Gamma) \otimes \mathcal{R}$ as a projectively transitive system in (1). See also Kutluhan, Lee, and Taubes [27–31].

may be used to compute \mathcal{L} in several examples, and we describe an infinite family of nonreversible Lagrangian concordances between prime knots.

1.5. Acknowledgements

We thank Lenny Ng and Danny Ruberman for helpful conversations, and the referee for many useful comments and suggestions. JAB was partially supported by NSF grant DMS-1104688. SS was partially supported by NSF postdoctoral fellowship DMS-1204387.

2. Preliminaries

In this section, we review projectively transitive systems and the constructions of sutured monopole homology, monopole knot homology, and our contact invariant from [3].

2.1. Projectively transitive systems

The following is a very terse review of *projectively transitive systems*; see [2, 3] for more details.

Definition 2.1. Suppose M_α and M_β are modules over a unital commutative ring \mathcal{R} . We say that elements $x, y \in M_\alpha$ are *equivalent* if $x = u \cdot y$ for some $u \in \mathcal{R}^\times$. Likewise, homomorphisms

$$f, g : M_\alpha \rightarrow M_\beta$$

are *equivalent* if $f = u \cdot g$ for some $u \in \mathcal{R}^\times$.

Remark 2.2. We will write $x \doteq y$ or $f \doteq g$ to indicate that two elements or homomorphisms are equivalent, and will denote their equivalence classes by $[x]$ or $[f]$.

Definition 2.3. Let \mathcal{R} be a unital commutative ring. A *projectively transitive system of \mathcal{R} -modules* consists of a set A together with:

- 1) a collection of \mathcal{R} -modules $\{M_\alpha\}_{\alpha \in A}$ and
- 2) a collection of equivalence classes of homomorphisms $\{g_\beta^\alpha\}_{\alpha, \beta \in A}$ such that:
 - a) elements of the equivalence class g_β^α are isomorphisms from M_α to M_β ,

- b) $g_\alpha^\alpha = [id_{M_\alpha}]$,
- c) $g_\gamma^\alpha = g_\gamma^\beta \circ g_\beta^\alpha$.

The class of projectively transitive systems of \mathcal{R} -modules forms a category $\mathcal{R}\text{-PSys}$ with the following notion of morphism.

Definition 2.4. A *morphism* of projectively transitive systems of \mathcal{R} -modules

$$F : (A, \{M_\alpha\}, \{g_\beta^\alpha\}) \rightarrow (B, \{N_\gamma\}, \{h_\delta^\gamma\})$$

is a collection of equivalence classes of homomorphisms $F = \{F_\gamma^\alpha\}_{\alpha \in A, \gamma \in B}$ such that:

- 1) elements of the equivalence class F_γ^α are homomorphisms from M_α to N_γ ,
- 2) $F_\delta^\beta \circ g_\beta^\alpha = h_\delta^\gamma \circ F_\gamma^\alpha$.

Note that F is an *isomorphism* iff the elements in each equivalence class F_γ^α are isomorphisms.

Remark 2.5. A collection of equivalence classes of homomorphisms $\{F_\gamma^\alpha\}$ with indices ranging over any nonempty subset of $A \times B$ can be uniquely completed to a morphism as long as this collection satisfies the compatibility in (2) where it makes sense.

Definition 2.6. An *element* of a projectively transitive system of \mathcal{R} -modules

$$x \in \mathcal{M} = (A, \{M_\alpha\}, \{g_\beta^\alpha\})$$

is a collection of equivalence classes of elements $x = \{x_\alpha\}_{\alpha \in A}$ such that:

- 1) elements of the equivalence class x_α are elements of M_α ,
- 2) $x_\beta = g_\beta^\alpha(x_\alpha)$.

Remark 2.7. As in Remark 2.5, a collection of equivalence classes of elements $\{x_\alpha\}$ with indices ranging over any nonempty subset of A can be uniquely completed to an element of \mathcal{M} as long as this collection satisfies the compatibility in (2) where it makes sense.

2.2. Sutured monopole homology

In this subsection, we review our refinement of Kronheimer and Mrowka's sutured monopole homology, following [2].

Suppose (M, Γ) is a *balanced sutured manifold* as in [3, Definition 2.10]. An *auxiliary surface* for (M, Γ) is a compact, connected, oriented surface F with $g(F) > 0$ and $\pi_0(\partial F) \cong \pi_0(\Gamma)$. Given such a surface, a closed tubular neighborhood $A(\Gamma)$ of Γ in ∂M , and an orientation-reversing diffeomorphism

$$h : \partial F \times [-1, 1] \rightarrow A(\Gamma)$$

which sends $\partial F \times \{\pm 1\}$ to $\partial(R_{\pm}(\Gamma) \setminus A(\Gamma))$, we form a *preclosure*

$$M' = M \cup_h F \times [-1, 1]$$

by gluing $F \times [-1, 1]$ to M according to h and rounding corners. The *balanced* condition on (M, Γ) ensures that M' has two diffeomorphic boundary components, $\partial_+ M'$ and $\partial_- M'$, which we may glue together by some diffeomorphism to form a closed 3-manifold Y containing a distinguished surface

$$R := \partial_+ M' = -\partial_- M' \subset Y.$$

In [25], Kronheimer and Mrowka define a *closure* of (M, Γ) to be any pair (Y, R) obtained in this way. Our definition of closure, as needed for naturality, is slightly more involved.

Definition 2.8 ([2]). A *marked closure* of (M, Γ) is a tuple $\mathcal{D} = (Y, R, r, m, \eta)$ consisting of:

- 1) a closed, oriented, 3-manifold Y ,
- 2) a closed, oriented, surface R with $g(R) \geq 2$,
- 3) an oriented, nonseparating, embedded curve $\eta \subset R$,
- 4) a smooth, orientation-preserving embedding $r : R \times [-1, 1] \hookrightarrow Y$,
- 5) a smooth, orientation-preserving embedding $m : M \hookrightarrow Y \setminus \text{int}(\text{Im}(r))$ such that:
 - a) m extends to a diffeomorphism

$$M \cup_h F \times [-1, 1] \rightarrow Y \setminus \text{int}(\text{Im}(r))$$

for some $A(\Gamma)$, F , h , as above,

b) m restricts to an orientation-preserving embedding

$$R_+(\Gamma) \setminus A(\Gamma) \hookrightarrow r(R \times \{-1\}).$$

The *genus* $g(\mathcal{D})$ refers to the genus of R .

Remark 2.9. Suppose $\mathcal{D} = (Y, R, r, m, \eta)$ is a marked closure of (M, Γ) . Then, the tuple

$$-\mathcal{D} := (-Y, -R, r, m, -\eta),$$

obtained by reversing the orientations of Y , R , and η , is a marked closure of $-(M, \Gamma) := (-M, -\Gamma)$, where r and m are the induced embeddings of $-R \times [-1, 1]$ and $-M$ into $-Y$.

Notation 2.10. For the rest of this paper, \mathcal{R} will be the *Novikov ring over \mathbb{Z}* , given by

$$\mathcal{R} = \left\{ \sum_{\alpha} c_{\alpha} t^{\alpha} \mid \alpha \in \mathbb{R}, c_{\alpha} \in \mathbb{Z}, \#\{\beta < n \mid c_{\beta} \neq 0\} < \infty \text{ for all } n \in \mathbb{Z} \right\}.$$

Following Kronheimer and Mrowka [25], we made the following definition in [2].

Definition 2.11. Given a marked closure $\mathcal{D} = (Y, R, r, m, \eta)$ of (M, Γ) , the *sutured monopole homology of \mathcal{D}* is the \mathcal{R} -module

$$\underline{SHM}(\mathcal{D}) := \widetilde{HM}_{\bullet}(Y|R; \Gamma_{\eta}).$$

Here, $\widetilde{HM}_{\bullet}(Y|R; \Gamma_{\eta})$ is shorthand for the monopole Floer homology of Y in the “bottommost” Spin^c structures relative to $r(R \times \{0\})$,

$$(3) \quad \widetilde{HM}_{\bullet}(Y|R; \Gamma_{\eta}) := \bigoplus_{\substack{\mathfrak{s} \in \text{Spin}^c(Y) \\ \langle c_1(\mathfrak{s}), [r(R \times \{0\})] \rangle = 2 - 2g(R)}} \widetilde{HM}_{\bullet}(Y, \mathfrak{s}; \Gamma_{r(\eta \times \{0\})}),$$

where, for each Spin^c structure \mathfrak{s} , $\Gamma_{r(\eta \times \{0\})}$ is the local system on the Seiberg-Witten configuration space $\mathcal{B}(Y, \mathfrak{s})$ with fiber \mathcal{R} specified by $r(\eta \times \{0\}) \subset Y$ as in [25, Section 2.2].

In [25], Kronheimer and Mrowka proved that the isomorphism class of $\underline{SHM}(\mathcal{D})$ is an invariant of (M, Γ) . We strengthened this in [2]: for any two

marked closures $\mathcal{D}, \mathcal{D}'$ of (M, Γ) , we constructed an isomorphism

$$\Psi_{\mathcal{D}, \mathcal{D}'} : \underline{SHM}(\mathcal{D}) \rightarrow \underline{SHM}(\mathcal{D}'),$$

well-defined up to multiplication by a unit in \mathcal{R} , such that the modules in $\{\underline{SHM}(\mathcal{D})\}_{\mathcal{D}}$ and the equivalence classes of maps in $\{\Psi_{\mathcal{D}, \mathcal{D}'}\}_{\mathcal{D}, \mathcal{D}'}$ form a projectively transitive system of \mathcal{R} -modules.

Definition 2.12. The *sutured monopole homology* of (M, Γ) is the projectively transitive system of \mathcal{R} -modules $\underline{\mathbf{SHM}}(M, \Gamma)$ given by the modules and the equivalence classes above.

Sutured monopole homology is functorial in the following sense. Suppose

$$f : (M, \Gamma) \rightarrow (M', \Gamma')$$

is a diffeomorphism of sutured manifolds and $\mathcal{D}' = (Y', R', r', m', \eta')$ is a marked closure of (M', Γ') . Then

$$(4) \quad \mathcal{D}'_f := (Y', R', r', m' \circ f, \eta')$$

is a marked closure of (M, Γ) . Let

$$id_{\mathcal{D}'_f, \mathcal{D}'} : \underline{SHM}(\mathcal{D}'_f) \rightarrow \underline{SHM}(\mathcal{D}')$$

be the identity map on $\underline{SHM}(\mathcal{D}'_f) = \underline{SHM}(\mathcal{D}')$. The equivalence classes of these identity maps can be completed to a morphism (as in Remark 2.5)

$$\underline{\mathbf{SHM}}(f) : \underline{\mathbf{SHM}}(M, \Gamma) \rightarrow \underline{\mathbf{SHM}}(M', \Gamma'),$$

which is an invariant of the isotopy class of f . We proved in [2] that these morphisms behave as expected under composition of diffeomorphisms, so that $\underline{\mathbf{SHM}}$ defines a functor from $\mathbf{DiffSut}$ to $\mathcal{R}\text{-PSys}$, where $\mathbf{DiffSut}$ is the category of balanced sutured manifolds and isotopy classes of diffeomorphisms between them.

2.3. Monopole knot homology

In this subsection, we review our refinement of Kronheimer and Mrowka's monopole knot homology, following [2].

Suppose K is an oriented knot in a closed 3-manifold Y and p is a basepoint on K . Let D^2 be the unit disk in the complex plane and let $S^1 = \partial D^2$. Suppose

$$\varphi : S^1 \times D^2 \rightarrow Y$$

is an embedding such that $\varphi(S^1 \times \{0\}) = K$ and $\varphi(\{1\} \times \{0\}) = p$. Let $Y(\varphi)$ be the balanced sutured manifold given by

$$Y(\varphi) := (Y \setminus \text{int}(\text{Im}(\varphi)), m_\varphi^+ \cup -m_\varphi^-),$$

where m_φ^\pm are the oriented meridians on $\partial Y(\varphi)$ given by

$$m_\varphi^\pm := \varphi(\{\pm 1\} \times \partial D^2).$$

The monopole knot homology $\mathbf{KHM}(Y, K, p)$ is defined more or less to be $\mathbf{SHM}(Y(\varphi))$. Of course, this does not technically make sense since the latter depends on φ . However, in [2], we defined a canonical isomorphism

$$\underline{\Psi}_{\varphi, \varphi'} : \mathbf{SHM}(Y(\varphi)) \rightarrow \mathbf{SHM}(Y(\varphi'))$$

for any two embeddings φ, φ' as above. These maps allow us to define $\mathbf{KHM}(Y, K, p)$ without ambiguity (see Definition 2.13). The map $\underline{\Psi}_{\varphi, \varphi'}$ is constructed in two steps, as described below.

We first consider the case in which $\text{Im}(\varphi') \subset \text{Im}(\varphi)$. Let N be a solid torus neighborhood of K with $\text{Im}(\varphi) \subset \text{int}(N)$. Let $f_t : Y \rightarrow Y, t \in [0, 1]$, be an ambient isotopy such that:

- 1) each f_t fixes p ,
- 2) each f_t restricts to the identity outside of N ,
- 3) $\text{Im}(f_1 \circ \varphi) = \text{Im}(\varphi')$,
- 4) f_1 sends the meridional disks $\varphi(\{\pm 1\} \times D^2)$ to the meridional disks $\varphi'(\{\pm 1\} \times D^2)$.

Then f_1 restricts to a diffeomorphism of sutured manifolds,

$$\bar{f}_1 : Y(\varphi) \rightarrow Y(\varphi'),$$

and we define $\underline{\Psi}_{\varphi, \varphi'}$ by

$$\underline{\Psi}_{\varphi, \varphi'} := \mathbf{SHM}(\bar{f}_1).$$

Next, we consider the case in which φ, φ' are arbitrary embeddings. Let φ'' be a third embedding with $\text{Im}(\varphi'') \subset \text{Im}(\varphi) \cap \text{Im}(\varphi')$. We define

$$\underline{\Psi}_{\varphi, \varphi'} := (\underline{\Psi}_{\varphi', \varphi''})^{-1} \circ \underline{\Psi}_{\varphi, \varphi''},$$

where the maps $\underline{\Psi}_{\varphi', \varphi''}$ and $\underline{\Psi}_{\varphi, \varphi''}$ are as defined previously.

We proved in [2] that these maps are well-defined and satisfy the transitivity relation

$$\underline{\Psi}_{\varphi, \varphi''} = \underline{\Psi}_{\varphi', \varphi''} \circ \underline{\Psi}_{\varphi, \varphi'}.$$

The projectively transitive systems in $\{\underline{\mathbf{SHM}}(Y(\varphi))\}_\varphi$ and the isomorphisms in $\{\underline{\Psi}_{\varphi, \varphi'}\}_{\varphi, \varphi'}$ thus form a *transitive system of projectively transitive systems of \mathcal{R} -modules*, which determines a larger projectively transitive system of \mathcal{R} -modules, leading to the following from [2].

Definition 2.13. The monopole knot homology $\underline{\mathbf{KHM}}(Y, K, p)$ is the projectively transitive system of \mathcal{R} -modules determined by $\{\underline{\mathbf{SHM}}(Y(\varphi))\}_\varphi$ and $\{\underline{\Psi}_{\varphi, \varphi'}\}_{\varphi, \varphi'}$.

When we do not wish to keep track of p , we will simply use the notation $\underline{\mathbf{KHM}}(Y, K)$.

Monopole knot homology is functorial in the following sense. Suppose f is a diffeomorphism from (Y, K, p) to (Y', K', p') . For each tubular neighborhood φ of K as defined above, f defines a diffeomorphism of balanced sutured manifolds,

$$\bar{f} : Y(\varphi) \rightarrow Y'(f \circ \varphi).$$

The map \bar{f} then induces a map

$$\underline{\mathbf{SHM}}(\bar{f}) : \underline{\mathbf{SHM}}(Y(\varphi)) \rightarrow \underline{\mathbf{SHM}}(Y'(f \circ \varphi)),$$

which then determines an isomorphism

$$\underline{\mathbf{KHM}}(f) : \underline{\mathbf{KHM}}(Y, K, p) \rightarrow \underline{\mathbf{KHM}}(Y', K', p').$$

This isomorphism is well-defined in that it does not depend on φ , which is to say the diagram

$$\begin{array}{ccc} \underline{\mathbf{SHM}}(Y(\varphi)) & \xrightarrow{\underline{\mathbf{SHM}}(\bar{f})} & \underline{\mathbf{SHM}}(Y'(f \circ \varphi)) \\ \underline{\Psi}_{\varphi, \varphi'} \downarrow & & \downarrow \underline{\Psi}_{f \circ \varphi, f \circ \varphi'} \\ \underline{\mathbf{SHM}}(Y(\varphi')) & \xrightarrow{\underline{\mathbf{SHM}}(\bar{f})} & \underline{\mathbf{SHM}}(Y'(f \circ \varphi')) \end{array}$$

commutes for all φ, φ' . Moreover, these isomorphisms are invariants of isotopy classes of based diffeomorphisms and respect composition in the obvious way (see [2, Theorem 8.5]).

2.4. The contact invariant in SHM

Suppose (M, Γ) is a balanced sutured manifold and ξ is a contact structure on M such that ∂M is convex and Γ divides the characteristic foliation of ∂M induced by ξ . We call the triple (M, Γ, ξ) a *sutured contact manifold*. In this subsection, we review the construction of the contact invariant

$$\psi(M, \Gamma, \xi) \in \underline{SHM}(-M, -\Gamma)$$

defined in [3] and list some of its properties.

An important notion is that of a *contact preclosure* of (M, Γ) . This is a preclosure M' of (M, Γ) together with a certain contact structure ξ' on M' extending ξ such that $\partial M'$ is convex with dividing set Γ' consisting of two parallel nonseparating curves on each component $\partial_{\pm} M'$. The negative region $R_-(\Gamma')$ restricted to $\partial_+ M'$ is an annulus bounded by these curves, and likewise for the positive region $R_+(\Gamma')$ on $\partial_- M'$. The details of the construction of contact preclosures can be found in [3, Subsection 3.1] but are not important for this paper.

Given a contact preclosure (M', ξ') , one can form a closed contact 3-manifold $(Y, \bar{\xi})$ by gluing $\partial_+ M'$ to $\partial_- M'$ by a diffeomorphism which identifies the positive region on one component with the negative region on the other, so that the distinguished surface $R := \partial_+ M' = -\partial_- M'$ is convex with negative region an annulus. One might call such a $(Y, \bar{\xi})$ a *contact closure* of (M, Γ, ξ) . In [3], we gave the slightly more involved definition below, as needed for naturality.

Definition 2.14. A *marked contact closure* of (M, Γ, ξ) consists of a marked closure $\mathcal{D} = (Y, R, r, m, \eta)$ of (M, Γ) together with a contact structure $\bar{\xi}$ on Y such that

- 1) m restricts to a contact embedding of $(M \setminus N(\Gamma), \xi)$ into $(Y, \bar{\xi})$ for some regular neighborhood $N(\Gamma)$ of Γ ,
- 2) this restriction of m extends to a contactomorphism

$$(M', \xi') \rightarrow (Y \setminus \text{int}(\text{Im}(r)), \bar{\xi})$$

for some contact preclosure (M', ξ') of (M, Γ, ξ) .

- 3) $r^*(\bar{\xi})$ is a $[-1, 1]$ -invariant contact structure on $R \times [-1, 1]$.
- 4) the curve $r(\eta \times \{0\})$ is dual to the core of the negative annular region of $r(R \times \{0\})$.

Suppose $(\mathcal{D} = (Y, R, r, m, \eta), \bar{\xi})$ is a marked contact closure of (M, Γ, ξ) . As shown in [3, Subsection 3.2], the fact that $r(R \times \{0\})$ is convex with negative region an annulus implies that the Spin^c structure $\mathfrak{s}_{\bar{\xi}}$ is a bottommost Spin^c structure on $-Y$ with respect to $r(-R \times \{0\})$, and hence the monopole Floer contact invariant $\psi(Y, \bar{\xi}) \in \widetilde{HM}_\bullet(-Y, \mathfrak{s}_{\bar{\xi}}; \Gamma_{-\eta})$ defined by Kronheimer and Mrowka [24] is in fact an element of $\widetilde{HM}_\bullet(-Y | -R; \Gamma_{-\eta}) = \underline{SHM}(-\mathcal{D})$. This leads to the following definition from [3].

Definition 2.15. Given a marked contact closure $(\mathcal{D} = (Y, R, r, m, \eta), \bar{\xi})$ of (M, Γ, ξ) of genus $g \geq g(M, \Gamma)$, we define $\psi^g(M, \Gamma, \xi)$ to be the element of $\underline{SHM}(-M, -\Gamma)$ determined by the equivalence class of

$$\psi(\mathcal{D}, \bar{\xi}) := \psi(Y, \bar{\xi}) \in \underline{SHM}(-\mathcal{D}),$$

in the sense of Remark 2.7.

Here $g(M, \Gamma) \geq 2$ denotes the minimum genus for which (M, Γ) admits a marked closure. We proved that $\psi^g(M, \Gamma, \xi)$ is well-defined for each g , per the following theorem.

Theorem 2.16. *If $(\mathcal{D}, \bar{\xi})$ and $(\mathcal{D}', \bar{\xi}')$ are two marked contact closures of (M, Γ, ξ) of the same genus, then*

$$\underline{\Psi}_{-\mathcal{D}, -\mathcal{D}'}(\psi(\mathcal{D}, \bar{\xi})) \doteq \psi(\mathcal{D}', \bar{\xi}').$$

Furthermore, we showed that for g sufficiently large the contact elements $\psi^g(M, \Gamma, \xi)$ are all equal, per the following theorem.

Theorem 2.17. *For every (M, Γ, ξ) , there is an integer $N(M, \Gamma, \xi)$ such that*

$$\psi^g(M, \Gamma, \xi) = \psi^h(M, \Gamma, \xi)$$

for all $g, h \geq N(M, \Gamma, \xi)$. Said differently, if $(\mathcal{D}, \bar{\xi})$ and $(\mathcal{D}', \bar{\xi}')$ are marked contact closures of (M, Γ, ξ) of genus at least $N(M, \Gamma, \xi)$, then

$$\underline{\Psi}_{-\mathcal{D}, -\mathcal{D}'}(\psi(\mathcal{D}, \bar{\xi})) \doteq \psi(\mathcal{D}', \bar{\xi}').$$

The constant $N(M, \Gamma, \xi)$ can be taken to be the minimum value of $\max(2, g(S) + |\partial S|)$ over all partial open book decompositions (S, P, h) which support (M, Γ, ξ) ; see [3, Definition 3.15]. We expect, however, that any g for which (M, Γ, ξ) admits a marked contact closure of genus g should suffice.

Theorem 2.17 motivated the following definition in [3].

Definition 2.18. We define

$$\psi(M, \Gamma, \xi) := \psi^g(M, \Gamma, \xi) \in \underline{\mathbf{SHM}}(-M, -\Gamma)$$

for any $g \geq N(M, \Gamma, \xi)$.

Below, we recall some properties of our contact invariant ψ (analogous properties hold for each ψ^g) that were proven in [3].

Proposition 2.19. *Suppose f is a contactomorphism from (M, Γ, ξ) to (M', Γ', ξ') . Then the induced map*

$$\underline{\mathbf{SHM}}(f) : \underline{\mathbf{SHM}}(-M, -\Gamma) \rightarrow \underline{\mathbf{SHM}}(-M', -\Gamma')$$

sends $\psi(M, \Gamma, \xi)$ to $\psi(M', \Gamma', \xi')$. In particular, the map on $\underline{\mathbf{SHM}}(-M, -\Gamma)$ induced by a contact isotopy preserves the contact invariant.

Proposition 2.20. *If (M, Γ, ξ) is overtwisted, then $\psi(M, \Gamma, \xi) = 0$.*

For the next two results, suppose (Y, ξ) is a closed contact 3-manifold and $Y(1)$ is the contact 3-manifold obtained by removing a Darboux ball. The first result below is a corollary of [3, Proposition 3.23].

Proposition 2.21. *If $\psi(Y, \xi) \neq 0$ then $\psi(Y(1)) \neq 0$.*

Corollary 2.22. *If (Y, ξ) is strongly symplectically fillable, then $\psi(Y(1)) \neq 0$.*

For the next result, suppose K is a Legendrian knot in the interior of (M, Γ, ξ) and that (M', Γ', ξ') is the result of contact $(+1)$ -surgery on K .

Proposition 2.23. *There is a morphism*

$$F_K : \underline{\mathbf{SHM}}(-M, -\Gamma) \rightarrow \underline{\mathbf{SHM}}(-M', -\Gamma')$$

which sends $\psi(M, \Gamma, \xi)$ to $\psi(M', \Gamma', \xi')$.

3. Invariants of Legendrian and transverse knots

In this section, we use our invariant of sutured contact manifolds together with a prescription of Stipsicz and Vértesi [45] to define invariants of Legendrian and transverse knots, as outlined in the introduction.

3.1. A Legendrian invariant

Suppose (K, p) is a based, oriented Legendrian knot in (Y, ξ) . Here, we define the invariant

$$\mathcal{L}(K) \in \underline{\mathbf{KHM}}(-Y, K, p)$$

described in the introduction. Roughly speaking, $\mathcal{L}(K)$ is the contact invariant of the sutured contact manifold obtained by removing a standard neighborhood of K and attaching a bypass so that the resulting dividing set consists of oppositely oriented meridians. We make this precise below.

Consider the coordinates $(\theta, (x, y))$ on $S^1 \times D^2$, where $\theta \in [0, 2\pi]/(0 \sim 2\pi)$ is identified with $e^{i\theta} \in S^1$ and (x, y) is identified with $x + yi \in D^2$. Let ξ_{leg} be the contact structure on $S^1 \times D^2$ given by

$$\xi_{leg} := \ker(\sin(\theta)dx + \cos(\theta)dy).$$

Every Legendrian knot has a neighborhood contactomorphic to $(S^1 \times D^2, \xi_{leg})$; such a neighborhood is called a *standard* neighborhood.

To define $\mathcal{L}(K)$, we first choose a contact embedding

$$\varphi : (S^1 \times D^2, \xi_{leg}) \rightarrow (Y, \xi)$$

such that $\varphi(S^1 \times \{0\}) = K$ and $\varphi(\{1\} \times \{0\}) = p$. The torus $\partial(\text{Im}(\varphi))$ is convex with respect to ξ . Furthermore, the dividing set on $\partial(\text{Im}(\varphi))$ consists of two parallel curves Γ of slope -1 with respect to the coordinate system determined by the meridian and longitude on $\partial(S^1 \times D^2)$ given by $\mu = \{1\} \times \partial D^2$ and $\lambda = S^1 \times \{1\}$, respectively.

Let (Y', Γ', ξ') be the sutured contact manifold obtained from the Legendrian knot complement $(Y(\varphi), \xi|_{Y(\varphi)})$ by attaching a *bypass* (roughly, a thickened neighborhood of half an overtwisted disk) along the arc $\alpha \subset \partial Y(\varphi)$ shown in Figure 1. This bypass attachment does not change the underlying topology of the knot complement, but changes the dividing set (and, hence, the contact structure) in a neighborhood of the arc α in the manner illustrated in the figure; we refer the reader to [3, 19] for more in-depth discussions of bypass attachments. In particular, note that Γ' consists of two

oppositely oriented meridians, so that (Y', Γ') and $Y(\varphi)$ are diffeomorphic. There are two different attaching arcs for bypasses which could produce such meridional sutures, and these bypasses are distinguished by the sign of their relative Euler classes; our particular choice is identified by the fact that union of the attaching arc c and an arc in Γ with boundary ∂c forms an oriented meridian, when oriented in the same way as the piece of Γ (which is itself oriented so that $\Gamma = \partial R_+(\Gamma)$). See [45, Figure 6] and the proof of [45, Theorem 1.5] for more detailed discussion.

We would like to pull the contact structure ξ' back to a contact structure on $Y(\varphi)$. Accordingly, let

$$(5) \quad f : Y(\varphi) \rightarrow (Y', \Gamma')$$

be a diffeomorphism which restricts to the identity map on

$$Y(\varphi) \setminus N = Y' \setminus N,$$

for some standard neighborhood N of K with $\text{Im}(\varphi) \subset \text{int}(N)$. Let $\xi_{K,\varphi}$ be the contact structure on $Y(\varphi)$ given by

$$\xi_{K,\varphi} = (f_*)^{-1}(\xi').$$

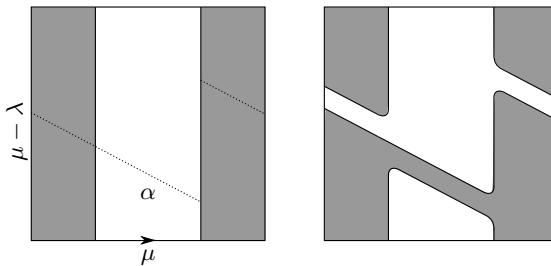

Figure 1: Left, the dividing set on $\partial Y(\varphi)$ with respect to the coordinate system $(\mu, \mu - \lambda)$. Right, after attaching a bypass along α to form (Y', ξ') . In both pictures the negative regions $R_-(\Gamma)$ and $R_-(\Gamma')$ are shaded.

We claim that $\xi_{K,\varphi}$ is well-defined up to contact isotopy. Indeed, given N we need only verify this on the neighborhood $N \cap Y(\varphi)$ of the boundary, which is topologically $T^2 \times [0, 1]$. The claim is then a consequence of the following technical lemma. (We refer the reader to [19] for the definition of *minimally twisting*.)

Lemma 3.1. *Suppose ξ is a tight, minimally twisting contact structure on $T^2 \times [0, 1]$ with dividing set consisting of two parallel curves on each boundary component, of slope ∞ on $T^2 \times \{0\}$ and -1 on $T^2 \times \{1\}$. Suppose f is a contactomorphism of $(T^2 \times [0, 1], \xi)$ which restricts to the identity on $T^2 \times \{1\}$ and preserves the dividing set on $T^2 \times \{0\}$. Then $f_*(\xi)$ is isotopic to ξ by an isotopy which is stationary on the boundary.*

Proof. The contact structure $f_*(\xi)$ is certainly tight and minimally twisting. Moreover, it has the same dividing set as ξ . By [19, Proposition 4.7], there are exactly two tight, minimally twisting contact structures on $T^2 \times [0, 1]$ with this dividing set, up to isotopy stationary on the boundary, distinguished by their relative Euler classes. But f acts trivially on homology since it restricts to the identity on $T^2 \times \{1\}$, which implies that the relative Euler class of ξ agrees with that of $f_*(\xi)$ and, therefore, that ξ and $f_*(\xi)$ are isotopic. \square

Any two choices of f and the particular bypass attachment used to construct $\xi_{K,\varphi}$ yield a contact structure on $N \cap Y(\varphi)$ satisfying the hypotheses of Lemma 3.1, with relative Euler class pinned down by the sign of the bypass (see the discussion in [45, Section 4]), so the resulting $\xi_{K,\varphi}$ are contact isotopic. That $\xi_{K,\varphi}$ is independent, up to isotopy, of the neighborhood N then follows from the fact that for any two such N , there is a third which is contained in both.

Definition 3.2. Given a contact embedding φ as above, we define $\mathcal{L}(K)$ to be the element of $\mathbf{KHM}(-Y, K, p)$ determined by the class

$$\mathcal{L}(K, \varphi) := \psi(Y(\varphi), \xi_{K,\varphi}) \in \mathbf{SHM}(-Y(\varphi)).$$

Since $\xi_{K,\varphi}$ is well-defined up to isotopy, the element $\mathcal{L}(K, \varphi)$ is well-defined by Proposition 2.19. We prove below that $\mathcal{L}(K)$ is well-defined:

Theorem 3.3. *The element $\mathcal{L}(K)$ is independent of the choices made in its construction.*

Proof. To prove that $\mathcal{L}(K)$ is well-defined, we must show that for any two contact embeddings φ, φ' , the canonical isomorphism

$$\underline{\Psi}_{\varphi, \varphi'} : \mathbf{SHM}(-Y(\varphi)) \rightarrow \mathbf{SHM}(-Y(\varphi'))$$

sends $\mathcal{L}(K, \varphi)$ to $\mathcal{L}(K, \varphi')$. It suffices to prove this in the case that $\text{Im}(\varphi') \subset \text{Im}(\varphi)$. Let N be a standard neighborhood of K with $\text{Im}(\varphi) \subset \text{int}(N)$, as

above. Let f_t be an ambient isotopy of Y , supported in N , of the sort used to define the map $\underline{\Psi}_{\varphi, \varphi'}$. Then

$$\underline{\Psi}_{\varphi, \varphi'}(\mathcal{L}(K, \varphi)) := \underline{\mathbf{SHM}}(\bar{f}_1)(\psi(Y(\varphi), \xi_{K, \varphi})) = \psi(Y(\varphi'), (\bar{f}_1)_*(\xi_{K, \varphi})),$$

where the second equality is by Proposition 2.19. We therefore wish to show that

$$\psi(Y(\varphi'), (\bar{f}_1)_*(\xi_{K, \varphi})) = \psi(Y(\varphi'), \xi_{K, \varphi'}) =: \mathcal{L}(K, \varphi').$$

It suffices to show that $(\bar{f}_1)_*(\xi_{K, \varphi})$ is isotopic to $\xi_{K, \varphi'}$. But this follows from Lemma 3.1 since these contact structures agree outside of N and are contactomorphic on $N \cap Y(\varphi')$ to contact structures on $T^2 \times [0, 1]$ as in the hypothesis of the lemma, with the same relative Euler classes. \square

3.2. A transverse invariant

Here, we prove some basic properties of the Legendrian invariant \mathcal{L} and use some of these to define the invariant of transverse knots mentioned in the introduction.

Our first result is that the Legendrian invariant behaves functorially with respect to contactomorphism in the following sense.

Proposition 3.4. *Suppose $(K, p) \subset (Y, \xi)$ and $(K', p') \subset (Y', \xi')$ are based, oriented Legendrian knots and $f : (Y, \xi) \rightarrow (Y', \xi')$ is a contactomorphism sending (K, p) to (K', p') . Then*

$$\underline{\mathbf{KHM}}(f)(\mathcal{L}(K)) = \mathcal{L}(K').$$

Proof. Let φ be a contact embedding of the sort used to define $\mathcal{L}(K)$, and let N be a standard neighborhood of K with $\text{Im}(\varphi) \subset \text{int}(N)$. The fact that f is a contactomorphism implies that $f \circ \varphi$ is a contact embedding of the sort used to define $\mathcal{L}(K')$. It suffices to prove that

$$\underline{\mathbf{SHM}}(\bar{f}) : \underline{\mathbf{SHM}}(-Y(\varphi)) \rightarrow \underline{\mathbf{SHM}}(-Y'(f \circ \varphi))$$

sends $\mathcal{L}(K, \varphi)$ to $\mathcal{L}(K', f \circ \varphi)$. We have that

$$\underline{\mathbf{SHM}}(\bar{f})(\mathcal{L}(K, \varphi)) := \underline{\mathbf{SHM}}(\bar{f})(\psi(Y(\varphi), \xi_{K, \varphi})) = \psi(Y'(f \circ \varphi), (\bar{f})_*(\xi_{K, \varphi})).$$

We therefore wish to show that

$$\psi(Y'(f \circ \varphi), (\bar{f})_*(\xi_{K, \varphi})) = \psi(Y'(f \circ \varphi), \xi_{K', f \circ \varphi}) := \mathcal{L}(K', f \circ \varphi).$$

It suffices to show that $(\bar{f})_*(\xi_{K,\varphi})$ and $\xi_{K',f\circ\varphi}$ are isotopic.

By the fact that f is a contactomorphism, the contact structures $(\bar{f})_*(\xi_{K,\varphi})$ and $\xi_{K',f\circ\varphi}$ agree outside $f(N)$; on the thickened torus $f(N) \cap Y'(f \circ \varphi)$, they are both tight and minimally twisting with the same relative Euler class and boundary conditions. Thus they are isotopic on this thickened torus rel boundary by [19] and Lemma 3.1, and extending this isotopy across the rest of $Y'(f \circ \varphi)$ as the identity we conclude that they are isotopic as claimed. \square

Corollary 3.5. *If (K, p) and (K', p') are Legendrian isotopic knots in (Y, ξ) , then there exists an isomorphism*

$$\underline{\mathbf{KHM}}(-Y, K, p) \rightarrow \underline{\mathbf{KHM}}(-Y, K', p')$$

which sends $\mathcal{L}(K)$ to $\mathcal{L}(K')$. \square

In order to construct our transverse invariant, we will prove that \mathcal{L} is preserved in an appropriate sense by negative stabilization (Theorem 3.7) and then use the fact that any two Legendrian approximations of a transverse knot have a common negative stabilization [16]. Unfortunately, naturality adds some technical complication to an otherwise simple construction, because we cannot canonically identify the $\underline{\mathbf{KHM}}$ invariants associated to two Legendrian isotopic knots, or to a Legendrian knot and its negative stabilization, or to a transverse knot and a Legendrian pushoff: their complements are not equal or even (in the latter two cases) contactomorphic but merely diffeomorphic, and any identification depends on a choice of diffeomorphism. In Proposition 3.6 and Theorem 3.7 below, we show that any diffeomorphism supported in a small tubular neighborhood of the knot will suffice to identify the elements $\mathcal{L}(K)$ in each $\underline{\mathbf{KHM}}$ invariant, and hence in Theorem 3.9 we conclude that we have a well-defined transverse invariant.

The following proposition makes the above precise for Legendrian isotopic knots, by showing that diffeomorphisms of the ambient manifold which are the identity outside a small neighborhood of a knot send the Legendrian invariant to the Legendrian invariant. It is a strengthening of Proposition 3.4 in the sense that the diffeomorphism need not be a contactomorphism on the given neighborhood of the knots.

Proposition 3.6. *Suppose (K, p) and (K', p') are based, oriented Legendrian knots in (Y, ξ) such that there exists a contactomorphism of (Y, ξ) which sends one to the other and restricts to the identity outside of a tubular neighborhood N of both knots. Then, for any diffeomorphism f of Y*

which restricts to the identity outside of N and sends (K, p) to (K', p') ,

$$\mathbf{KHM}(f)(\mathcal{L}(K)) = \mathcal{L}(K').$$

Proof. Let h be a contactomorphism of (Y, ξ) which sends (K, p) to (K', p') and restricts to the identity outside of N , whose existence is guaranteed in the hypothesis of the proposition. Let φ be a contact embedding of the sort used to define $\mathcal{L}(K)$, and let N_1 be a standard neighborhood of K with $\text{Im}(\varphi) \subset \text{int}(N_1)$ and $N_1 \subset N$. Let φ' be a contact embedding of the sort used to define $\mathcal{L}(K')$ with $\text{Im}(\varphi') \subset \text{Im}(h \circ \varphi) \cap \text{Im}(f \circ \varphi)$. It suffices to prove that

$$\underline{\Psi}_{f \circ \varphi, \varphi'} \circ \mathbf{SHM}(\bar{f}) : \mathbf{SHM}(-Y(\varphi)) \rightarrow \mathbf{SHM}(-Y(\varphi'))$$

sends $\mathcal{L}(K, \varphi)$ to $\mathcal{L}(K', \varphi')$. Let g_t be an ambient isotopy of Y , supported in N , of the sort used to define $\underline{\Psi}_{f \circ \varphi, \varphi'}$. Then

$$\begin{aligned} \underline{\Psi}_{f \circ \varphi, \varphi'}(\mathbf{SHM}(\bar{f})(\mathcal{L}(K, \varphi))) &:= \mathbf{SHM}(\bar{g}_1 \circ \bar{f})(\psi(Y(\varphi), \xi_{K, \varphi})) \\ &= \psi(Y(\varphi'), (\bar{g}_1 \circ \bar{f})_*(\xi_{K, \varphi})). \end{aligned}$$

We therefore wish to show that

$$\psi(Y(\varphi'), (\bar{g}_1 \circ \bar{f})_*(\xi_{K, \varphi})) = \psi(Y(\varphi'), \xi_{K', \varphi'}) := \mathcal{L}(K', \varphi').$$

For this, it suffices to show that $(\bar{g}_1 \circ \bar{f})_*(\xi_{K, \varphi})$ is isotopic to $\xi_{K', \varphi'}$. To prove this, we first note that

$$\underline{\Psi}_{h \circ \varphi, \varphi'}(\mathbf{SHM}(\bar{h})(\mathcal{L}(K, \varphi))) = \mathcal{L}(K', \varphi')$$

by Proposition 3.4 and the proof of Theorem 3.3. In fact, more is true. Let u_t be an ambient isotopy of Y , supported in N , of the sort used to define $\underline{\Psi}_{h \circ \varphi, \varphi'}$. It follows from the proofs of Proposition 3.4 and Theorem 3.3 that $(u_1 \circ \bar{h})_*(\xi_{K, \varphi})$ is isotopic to $\xi_{K', \varphi'}$. So, to show that $(\bar{g}_1 \circ \bar{f})_*(\xi_{K, \varphi})$ is isotopic to $\xi_{K', \varphi'}$, it suffices to prove that

$$((\bar{g}_1 \circ \bar{f})^{-1} \circ u_1 \circ \bar{h})_*(\xi_{K, \varphi})$$

is isotopic to $\xi_{K, \varphi}$. More generally, one can show, for any diffeomorphism F of $Y(\varphi)$ which restricts to the identity outside of N , that $F_*(\xi_{K, \varphi})$ is isotopic to $\xi_{K, \varphi}$. Indeed, up to isotopy, F restricts to the identity on $N \setminus N_1$. Then one only need compare the restrictions of $F_*(\xi_{K, \varphi})$ and $\xi_{K, \varphi}$ to the thickened

torus $N_1 \cap Y(\varphi)$. Lemma 3.1 shows that these restrictions are isotopic by an isotopy which is stationary on ∂N and thus extends to all of $Y(\varphi)$. \square

Given a Legendrian knot K , we will denote by K_+ and K_- its *positive* and *negative stabilizations*. These are certain Legendrian knots contained in a standard neighborhood of K which are smoothly isotopic to K in said neighborhood; see [16, 17] for more details. The result below is that positive stabilization kills \mathcal{L} while negative stabilization preserves it.

Theorem 3.7. *Suppose (K, p) is a based, oriented Legendrian knot in (Y, ξ) . Let (K_+, p_+) and (K_-, p_-) be stabilizations of K contained within a standard neighborhood N of K . Then $\mathcal{L}(K_+) = 0$. On the other hand, $\mathcal{L}(K_-)$ agrees with $\mathcal{L}(K)$ in the sense that for any diffeomorphism f of Y which restricts to the identity outside of N and sends (K, p) to (K_-, p_-) ,*

$$\mathbf{KHM}(f)(\mathcal{L}(K)) = \mathcal{L}(K_-).$$

Proof. In [45], Stipsicz and Vértesi show that if one removes a standard neighborhood of K_+ from (Y, ξ) and attaches a bypass to the complement as in Figure 1, then the result is overtwisted. It follows that $\mathcal{L}(K_+) = 0$.

The statement about $\mathcal{L}(K_-)$ follows from the fact, shown in [45], that the result of attaching a bypass to the complement of a standard neighborhood of K , as prescribed in Figure 1, is contactomorphic to the analogous construction for K_- . To make this precise, let φ be a contact embedding of the sort used to define $\mathcal{L}(K)$ with $\text{Im}(\varphi) \subset \text{int}(N)$. Let φ_- be a contact embedding of the sort used to define $\mathcal{L}(K_-)$ with $\text{Im}(\varphi_-) \subset \text{Im}(f \circ \varphi)$. It suffices to prove that

$$\underline{\Psi}_{f \circ \varphi, \varphi_-} \circ \mathbf{SHM}(\bar{f}) : \mathbf{SHM}(-Y(\varphi)) \rightarrow \mathbf{SHM}(-Y(\varphi_-))$$

sends $\mathcal{L}(K, \varphi)$ to $\mathcal{L}(K_-, \varphi_-)$. Let g_t be an ambient isotopy of Y , supported in N , of the sort used to define $\underline{\Psi}_{f \circ \varphi, \varphi_-}$. Then, just as in the proof of Proposition 3.6, it suffices to prove that $(\bar{g}_1 \circ \bar{f})_*(\xi_{K, \varphi})$ is isotopic to ξ_{K_-, φ_-} . It follows from Stipsicz and Vértesi’s work in [45] that there exists a contactomorphism

$$h : (Y(\varphi), \xi_{K, \varphi}) \rightarrow (Y(\varphi_-), \xi_{K_-, \varphi_-})$$

which restricts to the identity outside of N . So, to show that $(\bar{g}_1 \circ \bar{f})_*(\xi_{K, \varphi})$ is isotopic to ξ_{K_-, φ_-} , it suffices to prove that

$$((\bar{g}_1 \circ \bar{f})^{-1} \circ h)_*(\xi_{K, \varphi})$$

is isotopic to $\xi_{K,\varphi}$. But this follows from the argument at the end of the proof of Proposition 3.6. □

The behavior of \mathcal{L} under negative stabilization means that we can use it to define an invariant of transverse knots via Legendrian approximation as described below.

Consider the coordinates $(\theta, (r, \phi))$ on $S^1 \times D^2$, where $\theta \in [0, 2\pi]/(0 \sim 2\pi)$ is identified with $e^{i\theta} \in S^1$ and (r, ϕ) is identified with $re^{i\phi} \in D^2$. For $\delta > 0$, let ξ_δ be the contact structure on $S^1 \times D^2$ given by

$$\xi_\delta := \ker(d\theta + \delta r^2 d\phi)$$

in these coordinates. Every transverse knot has a neighborhood contactomorphic to $(S^1 \times D^2, \xi_\delta)$ for some δ ; such a neighborhood is called a *standard neighborhood*.

Suppose (K, p) is a based, oriented transverse knot in (Y, ξ) . We define the transverse invariant $\mathcal{T}(K) \in \mathbf{KHM}(-Y, K, p)$ as follows (see [17] for the definition of *Legendrian pushoff*).

Definition 3.8. Let N be a standard neighborhood of (K, p) and choose a Legendrian pushoff $(K', p') \subset N$ of K . Let f be a diffeomorphism of Y which restricts to the identity outside of N and sends (K', p') to (K, p) . We define

$$\mathcal{T}(K) := \mathbf{KHM}(f)(\mathcal{L}(K')) \in \mathbf{KHM}(-Y, K, p).$$

We prove below that $\mathcal{T}(K)$ is well-defined. The key idea is that any two Legendrian pushoffs in a small enough neighborhood of K have negative stabilizations within that neighborhood which are Legendrian isotopic, so by applying Theorem 3.7 and then Proposition 3.6 it will follow that we can naturally identify the Legendrian invariants of the original pair of pushoffs.

Theorem 3.9. *The element $\mathcal{T}(K)$ is independent of the choices made in its construction.*

Proof. We must show that $\mathcal{T}(K)$ is independent of N , (K', p') , and f .

First, fix N and (K', p') . Suppose f and g are two diffeomorphisms of Y which restrict to the identity outside of N and send (K', p') to (K, p) . Then $f^{-1} \circ g$ also restricts to the identity outside of N and sends (K', p') to itself. Since there exists a contactomorphism of (Y, ξ) with the same property,

namely the identity map, Proposition 3.6 implies that

$$\underline{\mathbf{KHM}}(f^{-1} \circ g)(\mathcal{L}(K')) = \mathcal{L}(K'),$$

which implies that

$$\underline{\mathbf{KHM}}(f)(\mathcal{L}(K')) = \underline{\mathbf{KHM}}(g)(\mathcal{L}(K')).$$

Thus, for fixed N and (K', p') , the class $\mathcal{T}(K)$ is independent of the diffeomorphism f in its definition.

Now, suppose (K'_1, p'_1) and (K'_2, p'_2) are Legendrian pushoffs of K in N . According to [16] there exists a Legendrian knot $(K''_i, p''_i) \subset N$, for each $i = 1, 2$, which is the result of negatively stabilizing (K'_i, p'_i) some number of times such that (K''_1, p''_1) and (K''_2, p''_2) are isotopic by an isotopy supported in N . For $i = 1, 2$, let g_i be a diffeomorphism of Y which restricts to the identity outside of N and sends (K'_i, p'_i) to (K''_i, p''_i) . Similarly, let h_i be a diffeomorphism of Y which restricts to the identity outside of N and sends (K''_i, p''_i) to (K, p) . Then $h_i \circ g_i$ is a diffeomorphism of Y which restricts to the identity outside of N and sends (K'_i, p'_i) to (K, p) . To show that $\mathcal{T}(K)$ is independent of the Legendrian pushoff, it suffices to show that

$$(6) \quad \underline{\mathbf{KHM}}(h_1 \circ g_1)(\mathcal{L}(K'_1)) = \underline{\mathbf{KHM}}(h_2 \circ g_2)(\mathcal{L}(K'_2)).$$

By Theorem 3.7, we have that

$$\underline{\mathbf{KHM}}(g_i)(\mathcal{L}(K'_i)) = \mathcal{L}(K''_i)$$

for $i = 1, 2$, so (6) becomes

$$\underline{\mathbf{KHM}}(h_1)(\mathcal{L}(K''_1)) = \underline{\mathbf{KHM}}(h_2)(\mathcal{L}(K''_2)),$$

or, equivalently,

$$\underline{\mathbf{KHM}}(h_2^{-1} \circ h_1)(\mathcal{L}(K''_1)) = \mathcal{L}(K''_2).$$

But this is true by Proposition 3.6 since there exists a contactomorphism of (Y, ξ) which restricts to the identity outside of N and sends (K''_1, p''_1) to (K''_2, p''_2) .

We have thus shown that for a fixed N , the class $\mathcal{T}(K)$ is independent of (K', p') and f . That this class is also independent of N follows from the fact that for any two such standard neighborhoods, there exists a third contained in both. □

The next two results are straightforward analogues of Proposition 3.4 and Corollary 3.5; we omit their proofs.

Proposition 3.10. *Suppose $(K, p) \subset (Y, \xi)$ and $(K', p') \subset (Y', \xi')$ are based, oriented transverse knots and $f : (Y, \xi) \rightarrow (Y', \xi')$ is a contactomorphism sending (K, p) to (K', p') . Then*

$$\underline{\mathbf{KHM}}(f)(\mathcal{T}(K)) = \mathcal{T}(K').$$

Corollary 3.11. *If (K, p) and (K', p') are transversely isotopic knots in (Y, ξ) , then there exists an isomorphism*

$$\underline{\mathbf{KHM}}(-Y, K, p) \rightarrow \underline{\mathbf{KHM}}(-Y, K', p')$$

which sends $\mathcal{T}(K)$ to $\mathcal{T}(K')$.

3.3. Additional properties of \mathcal{L}

Here, we describe some additional properties satisfied by \mathcal{L} which are analogous to those satisfied by the LOSS invariant [33, 37, 42] and the second author’s invariant ℓ from [43]. We will omit basepoints from our notation for convenience and because they are not so relevant to the results. The first result below follows almost exactly as in the proof of Proposition 2.23 (given in [3]); we will therefore omit it.

Proposition 3.12. *Let $K, S \subset (Y, \xi)$ be disjoint Legendrian knots, and let (Y', ξ') be the contact manifold obtained by a contact $(+1)$ -surgery along S . If K has image K' in Y' , then there is a map*

$$\underline{\mathbf{KHM}}(-Y, K) \rightarrow \underline{\mathbf{KHM}}(-Y', K')$$

which sends $\mathcal{L}(K)$ to $\mathcal{L}(K')$. □

The next proposition is helpful in computing the invariant \mathcal{L} in certain cases.

Proposition 3.13. *Suppose $U \subset (Y, \xi)$ is a Legendrian unknot with $tb(U) = -1$ contained inside a Darboux ball in (Y, ξ) . Then there is an isomorphism*

$$\underline{\mathbf{SHM}}(-Y(1)) \rightarrow \underline{\mathbf{KHM}}(-Y, U)$$

which sends $\psi(Y(1))$ to $\mathcal{L}(U)$.

Proof. Let $B^3 \subset Y$ be a Darboux ball containing U and let $Y(1)$ refer to the sutured contact manifold obtained by removing a smaller Darboux ball $(B^3)' \subset B^3$ from Y . Note that one can attach a contact 1-handle to $Y(1)$ so as to obtain a sutured manifold, often denoted by $Y(U)$, which is the complement of a regular neighborhood $N \subset B^3$ of U with two meridional sutures. This handle is topologically a 1-handle attached to the dividing curve Γ of $Y(1)$ along disk neighborhoods of a pair of points in Γ , and its contact structure is specified by extending $\xi|_{Y(1)}$ across the handle (i.e., to all of $Y(U)$) in the unique way up to isotopy for which its restriction to the handle is tight.

One can identify $Y(U)$ with $Y(\varphi)$ for some embedding φ as in Subsection 2.3. As shown in [3, Subsection 4.2], this contact 1-handle attachment gives rise to an isomorphism

$$\underline{\mathbf{SHM}}(-Y(1)) \rightarrow \underline{\mathbf{SHM}}(-Y(U)) \cong \underline{\mathbf{KHM}}(-Y, U).$$

Let ξ_U be the contact structure on $Y(U)$ induced from that on $Y(1)$. It follows from [3, Corollary 4.14] that the map above sends $\psi(Y(1))$ to $\psi(Y(U), \xi_U)$. To complete the proof of Proposition 3.13, it suffices to check that $(Y(U), \xi_U)$ is contactomorphic to the contact structure on $Y(U)$ which defines $\mathcal{L}(U)$; namely, the contact structure obtained by removing a standard neighborhood of U (which we can assume is contained in B^3) and then attaching a bypass as described in Subsection 3.1. Since both this construction and the 1-handle attachment above are performed in a Darboux ball, it suffices to check this in the case that $(Y, \xi) = (S^3, \xi_{std})$. In this case, $Y(U)$ is a solid torus with two longitudinal sutures. As there is a unique isotopy class of tight contact structures on such a torus [19], it suffices to check that both ξ_U and the contact structure defining $\mathcal{L}(U)$ are tight. We know that ξ_U is tight since $\psi(Y(U), \xi_U)$ is identified with $\psi(Y(1))$ by the isomorphism above, and $\psi(Y(1)) \neq 0$ in this case by, for example, Corollary 2.22. The fact that the contact structure defining $\mathcal{L}(U)$ is tight follows from the fact that the LOSS invariant of the $tb = -1$ unknot in (S^3, ξ_{std}) is nonzero and the fact that this LOSS invariant is the Heegaard Floer contact invariant of the contact structure of interest [45]. (It is possible to give a slightly longer, but self-contained—i.e., independent of results in Heegaard Floer homology—proof.) \square

Combined with Proposition 2.21, this implies the following.

Corollary 3.14. *If $\psi(Y, \xi) \neq 0$, then $\mathcal{L}(U) \neq 0$.* \square

Propositions 3.12 and 3.13 admit the following additional corollaries. The proof of each is identical to that of the corresponding statement in [43, Section 5], with \mathcal{L} in place of ℓ . The first result below is an analogue of a theorem of Sahamie [42, Theorem 6.1].

Corollary 3.15. *Suppose K is a Legendrian knot in (Y, ξ) and let (Y', ξ') be the result of contact $(+1)$ -surgery on K . Then there exists a map*

$$\underline{\mathbf{KHM}}(-Y, K) \rightarrow \underline{\mathbf{SHM}}(-Y'(1))$$

which sends $\mathcal{L}(K)$ to $\psi(Y'(1))$. Thus, if $\psi(Y', \xi') \neq 0$, then $\mathcal{L}(K) \neq 0$. \square

The following is valid only over $\mathcal{R}/2\mathcal{R} := \mathcal{R} \otimes_{\mathbb{Z}} \mathbb{Z}/2\mathbb{Z}$ (its proof involves the surgery exact triangle in monopole Floer homology, which has only been established in characteristic two). The argument, which we sketch since we will use this corollary later, is originally due to Lisca and Stipsicz [34, Section 3].

Corollary 3.16. *Suppose K is a Legendrian knot in (S^3, ξ_{std}) with slice genus $g_s(K) > 0$ and $tb(K) = 2g_s - 1$. Then $\mathcal{L}(K) \neq 0$.*

Proof. There is a surgery exact triangle involving the mirror $m(K)$, of the form

$$\cdots \rightarrow \widetilde{HM}(S^3) \rightarrow \widetilde{HM}(S^3_{-2g_s}(m(K))) \rightarrow \widetilde{HM}(S^3_{-2g_s+1}(m(K))) \rightarrow \cdots .$$

The first map can be viewed as a cobordism from $-S^3$ to $-S^3_{2g_s}(K)$ corresponding to contact $+1$ -surgery on K , so by [21] it sends $\psi(S^3, \xi_{std}) \neq 0$ to $\psi(Y', \xi')$. This map is injective since the cobordism from $S^3_{-2g_s+1}(m(K))$ to S^3 induces the zero map – capping off a Seifert surface for $m(K)$ inside the 2-handle yields a surface Σ of genus g_s and self-intersection $2g_s - 1$, violating the adjunction inequality – so $\psi(Y', \xi')$ is nonzero and Corollary 3.15 applies. \square

Finally, note that Proposition 2.20 immediately implies the following.

Corollary 3.17. *Suppose K is a Legendrian knot in (Y, ξ) and the complement of K is overtwisted. Then $\mathcal{L}(K) = 0$. \square*

4. A map induced by Lagrangian concordances

The following relation on the set of Legendrian knots in a closed contact 3-manifold (Y, ξ) was introduced by Chantraine [6].

Definition 4.1. Let K_- and K_+ be Legendrian knots in (Y, ξ) parametrized by maps $\gamma_{\pm} : S^1 \rightarrow Y$. We say that K_- is *Lagrangian concordant* to K_+ if there is a Lagrangian cylinder

$$L : S^1 \times \mathbb{R} \hookrightarrow Y \times \mathbb{R}$$

in the symplectization of Y and a constant $T > 0$ such that $L(s, t) = \gamma_-(s)$ for all $t \leq -T$ and $L(s, t) = \gamma_+(s)$ for all $t \geq T$. We will use L to refer both to this map and to its image.

Chantraine showed that tb and r are Lagrangian concordance invariants, and the second author showed in [43] that the Legendrian invariant ℓ is well-behaved under Lagrangian concordance as well. In this section we will prove similar results about the effect of Lagrangian concordance on the invariant \mathcal{L} . Our main result is Theorem 1.2, which we restate here.

Theorem 1.2. Suppose K_- and K_+ are Legendrian knots in (Y, ξ) and K_- is Lagrangian concordant to K_+ . Then there is a map

$$\underline{\mathbf{KHM}}(-Y, K_+) \rightarrow \underline{\mathbf{KHM}}(-Y, K_-)$$

which sends $\mathcal{L}(K_+)$ to $\mathcal{L}(K_-)$.

The idea behind the proof is to replace a model neighborhood of the concordance $L \subset Y \times I$ with a certain symplectization so as to obtain an exact symplectic cobordism from a contact closure of the complement of K_- to a contact closure of the complement of K_+ , where these complements are equipped with the contact structures used to define the invariants $\mathcal{L}(K_{\pm})$. We then use the fact that the monopole Floer contact invariant for closed contact manifolds is functorial with respect to the maps induced by exact symplectic cobordisms (see [21] and the discussion in [3, Subsection 2.3]).

Proof of Theorem 1.2. Let α be a contact form for (Y, ξ) . By Definition 4.1, there exists a Lagrangian cylinder $L \subset (Y \times I, d(e^t \alpha))$ with $L \cap (Y \times \{\pm T\}) = K_{\pm} \times \{\pm T\}$, where $I = [-T - \epsilon, T + \epsilon]$ for some $\epsilon, T > 0$. Observe that L is *exact*, meaning that the form $e^t \alpha|_L$ is exact. It suffices to show that $e^t \alpha$ vanishes on $H_1(L; \mathbb{R})$. For this, note that $H_1(L; \mathbb{R})$ is generated by the class

of $K_- \times \{-T\}$ and

$$\int_{K_- \times \{-T\}} e^t \alpha = e^{-T} \int_{K_-} \alpha = 0$$

since K_- is Legendrian. The Lagrangian cylinder $L_- := K_- \times I \subset (Y \times I, d(e^t \alpha))$ is similarly exact. The Weinstein Tubular Neighborhood Theorem therefore gives an *exact* symplectomorphism

$$\varphi : N(L_-) \rightarrow N(L),$$

from a neighborhood of one Lagrangian to a neighborhood of the other. Exactness in this context means that if $d\lambda_-$ and $d\lambda$ are symplectic forms on the neighborhoods $N(L_-)$ and $N(L)$, then $\varphi^* \lambda - \lambda_- = df$ for some function $f : N(L_-) \rightarrow \mathbb{R}$. We are free to choose the identification $\varphi|_{L_-} : L_- \xrightarrow{\sim} L$ to be the identity on $K_- \times [-T - \epsilon, -T]$, so that $df \equiv 0$ on $N(L_-) \cap (Y \times [-T - \epsilon, -T])$. Since f is only determined up to a constant, we may then require that $f \equiv 0$ on $N(L_-) \cap (Y \times [-T - \epsilon, -T])$.

By shrinking $N(L_-)$ and $N(L)$ if necessary, we can assume that $N(L_-)$ is of the form $N(K_-) \times I$, where $N(K_-)$ is a standard neighborhood of K_- in (Y, ξ) . Let us identify $N(K_-)$ with $(S^1 \times D_a^2, \xi_{leg})$, where $D_a^2 \subset \mathbb{C}$ refers to the disk centered at the origin of radius a , so that φ can be thought of as a map

$$\varphi : (S^1 \times D_a^2) \times I \rightarrow N(L).$$

Note that φ sends $(S^1 \times D_a^2) \times \{\pm(T + \epsilon)\}$ to a standard neighborhood of K_{\pm} .

Let Y_- be the sutured contact manifold obtained from the sutured Legendrian knot complement $Y \setminus (S^1 \times D_1^2)$, which is defined using the above identification of $N(K_-) \subset Y$ with $S^1 \times D_2^2$, by attaching a bypass as prescribed in Subsection 3.1 (for the construction of $\mathcal{L}(K_-)$). We can assume that the contact structure on Y_- agrees with ξ outside of $S^1 \times D_{1.5}^2$. Let $\mathcal{D}_- = ((\bar{Y}_-, R_-, r_-, m_-, \eta_-), \bar{\xi}_-)$ be a marked contact closure of Y_- , where \bar{Y}_- is built from a contact preclosure of Y_- by attaching a $[-1, 1]$ -invariant contact structure on $R_- \times [-1, 1]$, so that r_- and m_- are inclusion maps. Let

$$Z = \bar{Y}_- \setminus (Y_- \setminus (S^1 \times D_2^2)),$$

and let A refer to the regions of Y and Z given by $S^1 \times (D_2^2 \setminus D_{1.5}^2)$. Let (X, ω) be the symplectic manifold formed by gluing the symplectization

$Z \times I$ to the complement $(Y \times I) \setminus \varphi((S^1 \times D_{1.5}^2) \times I)$ by the map

$$\varphi : A \times I \rightarrow \varphi(A \times I),$$

as depicted in Figure 2.

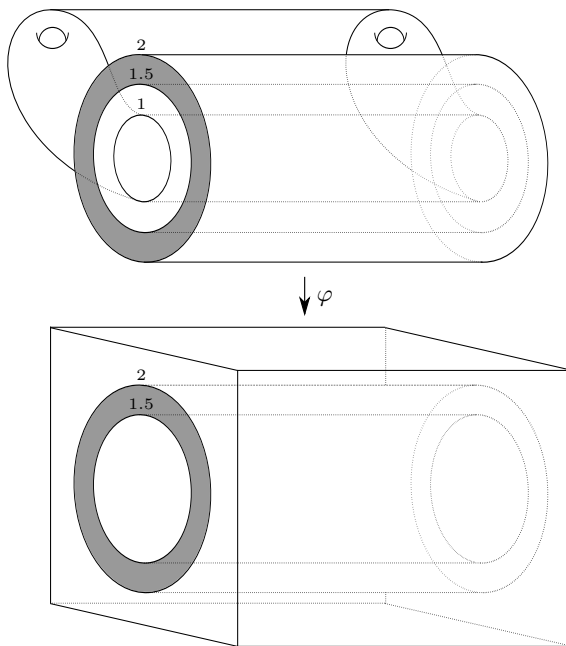

Figure 2: Top, a schematic of Z , with the region A shown in gray. Bottom, a schematic of $(Y \times I) \setminus \varphi((S^1 \times D_{1.5}^2) \times I)$, with $\varphi(A)$ shown in gray.

Let Y_{\pm}^{φ} be the sutured contact manifold obtained from the sutured Legendrian knot complement $(Y \times \{\pm(T + \epsilon)\}) \setminus \varphi((S^1 \times D_1^2) \times \{\pm(T + \epsilon)\})$ by attaching a bypass as prescribed in Subsection 3.1. By construction, (X, ω) is a symplectic cobordism from $(\bar{Y}_-^{\varphi}, \bar{\xi}_-^{\varphi})$ to $(\bar{Y}_+^{\varphi}, \bar{\xi}_+^{\varphi})$, where $(\bar{Y}_{\pm}^{\varphi}, \bar{\xi}_{\pm}^{\varphi})$ is the contact manifold underlying a marked contact closure

$$\mathcal{D}_{\pm}^{\varphi} = ((\bar{Y}_{\pm}^{\varphi}, R_{\pm}^{\varphi}, r_{\pm}^{\varphi}, m_{\pm}^{\varphi}, \eta_{\pm}^{\varphi}), \bar{\xi}_{\pm}^{\varphi})$$

of Y_{\pm}^{φ} (the additional data is naturally inherited from \mathcal{D}_-). In particular, the Legendrian invariant $\mathcal{L}(K_{\pm}) \in \mathbf{KHM}(-Y, K_{\pm})$ is represented by the contact

class

$$\psi(\bar{Y}_\pm^\varphi, \bar{\xi}_\pm^\varphi) \in SHM(-\mathcal{D}_\pm^\varphi) = \widetilde{HM}_\bullet(-\bar{Y}_\pm^\varphi | -R_\pm^\varphi; \Gamma_{-\eta_\pm^\varphi}).$$

To complete the proof of Theorem 1.2, it therefore suffices to show that the induced map

$$(7) \quad \widetilde{HM}_\bullet(X | -R^\varphi; \Gamma_{-\nu}) : \widetilde{HM}_\bullet(-\bar{Y}_+^\varphi | -R_+^\varphi; \Gamma_{-\eta_+^\varphi}) \rightarrow \widetilde{HM}_\bullet(-\bar{Y}_-^\varphi | -R_-^\varphi; \Gamma_{-\eta_-^\varphi})$$

sends $\psi(\bar{Y}_+^\varphi, \bar{\xi}_+^\varphi)$ to $\psi(\bar{Y}_-^\varphi, \bar{\xi}_-^\varphi)$, up to multiplication by a unit in \mathcal{R} , where $\nu = \eta_-^\varphi \times I \subset Z \times I \subset X$ is a cylindrical cobordism from η_-^φ to η_+^φ . This would follow from the work in [21] (see also [3, Theorem 2.22 & Remark 2.24]) if we knew that (X, ω) were an *exact* symplectic cobordism from $(Y_-^\varphi, \xi_-^\varphi)$ to $(Y_+^\varphi, \xi_+^\varphi)$. This is true after a slight modification (replacing X with \tilde{X} below).

We first show that the 2-form ω is exact. Suppose λ_- and λ are global primitives for the symplectic forms on the pieces $Z \times I$ and $(Y \times I) \setminus \varphi((S^1 \times D_{1.5}^2) \times I)$ coming from the Liouville vector field ∂_t . Since φ is an exact symplectomorphism, we have that $\varphi^*\lambda - \lambda_- = df$ and $d\lambda = \omega$ on the intersection of these pieces, which we will identify as $A \times I$. Let $\rho : A \rightarrow [0, 1]$ be a smooth cutoff function which is equal to 1 on a neighborhood of $S^1 \times D_2^2$ and 0 on a neighborhood of $S^1 \times D_{1.5}^2$. Define the 1-form

$$\lambda_X = \begin{cases} \lambda_- & \text{on } (Z \setminus A) \times I \\ \lambda_- + d(\rho f) & \text{on } A \times I \\ \lambda & \text{on } (Y \times I) \setminus \varphi((S^1 \times D_2^2) \times I). \end{cases}$$

Then λ_X is a globally defined primitive for ω , and its restriction to the boundary component \bar{Y}_-^φ is a contact form for $\bar{\xi}_-^\varphi$, since $f \equiv 0$ near this boundary component. On the other hand, $\omega|_{\bar{Y}_+^\varphi} = d\lambda_+$ for some contact form λ_+ for $\bar{\xi}_+^\varphi$, but we do not know that $\lambda_X|_{\bar{Y}_+^\varphi}$ is itself a contact form because of the $d(\rho f)$ term. To remedy this, we apply a result of Eliashberg [14, Proposition 3.1]. His result says that we can glue a symplectic $(\bar{Y}_+^\varphi \times [1, C], \Omega)$ to $\bar{Y}_+^\varphi \subset \partial X$ so that Ω is an exact 2-form whose primitive agrees with the primitive λ_X of ω near $\bar{Y}_+^\varphi \times \{1\}$ and Ω is the symplectization of \bar{Y}_+^φ near $\bar{Y}_+^\varphi \times \{C\}$. The result is a symplectic form $\tilde{\omega} = d\tilde{\lambda}$ on the cobordism

$$\tilde{X} = X \cup_{\bar{Y}_+^\varphi} (\bar{Y}_+^\varphi \times [1, C])$$

from \bar{Y}_-^φ to \bar{Y}_+^φ so that $\tilde{\lambda}$ restricts to contact forms for $(\bar{Y}_-^\varphi, \bar{\xi}_-^\varphi)$ and $(\bar{Y}_+^\varphi, \bar{\xi}_+^\varphi)$. Replacing X with \tilde{X} in (7), we have the desired result. \square

Remark 4.2. A *decorated* concordance $(L, \gamma) \subset Y \times I$ from (K_-, p_-) to (K_+, p_+) is a concordance L from K_- to K_+ together with an embedded arc $\gamma \subset L$ from p_- to p_+ . Based on Juhász's work [22], we expect that such an (L, γ) should induce a well-defined map (i.e., one that is independent of the auxiliary choices in its construction)

$$F_{(L, \gamma)} : \mathbf{KHM}(-Y, K_+, p_+) \rightarrow \mathbf{KHM}(-Y, K_-, p_-),$$

defined in a manner similar to the construction of the map in Theorem 1.2. More generally, we expect that decorated *cobordisms* between based knots should induce well-defined maps on \mathbf{KHM} , and that there should be an analogue of Theorem 1.2 for exact Lagrangian cobordisms of arbitrary genus. It is worth noting that, even without such an analogue, we can prove the following.

Lemma 4.3. *Suppose U is the Legendrian unknot in (S^3, ξ_{std}) with $tb = -1$. If U is exact Lagrangian cobordant to a Legendrian knot K with $g_s(K) > 0$, then $\mathcal{L}(K) \neq 0$ over $\mathcal{R}/2\mathcal{R}$.*

Proof. The existence of such a cobordism implies, by [6, Theorem 1.3], that $tb(K) = 2g_s(K) - 1$. Corollary 3.16 then implies that $\mathcal{L}(K) \neq 0$ over $\mathcal{R}/2\mathcal{R}$. \square

5. Examples and nonreversible Lagrangian concordances

We end with some examples. The first two illustrate how Theorem 1.2 can be used to deduce the nonvanishing of \mathcal{L} . All provide new examples of nonreversible Lagrangian concordances.

Example 5.1. For the first example (suggested by Lenny Ng), consider the Legendrian knots represented by the grid diagrams in Figure 3 (which can be converted to front diagrams by smoothing all northeast and southwest corners and rotating 45° counterclockwise). This figure describes a Lagrangian concordance from a negative stabilization U_- of the $tb = -1$ Legendrian unknot to a Legendrian representative K of the knot $m(8_{20})$ with $(tb(K), r(K)) = (-2, -1)$. Proposition 3.13 tells us that $\mathcal{L}(U) \neq 0$. Theorem 3.7 then implies that $\mathcal{L}(U_-) \neq 0$. We may therefore conclude from Theorem 1.2 that $\mathcal{L}(K) \neq 0$ as well.

Example 5.2. For the next example, consider Figure 4, which describes a Lagrangian concordance from a negative stabilization C_- of a Legendrian

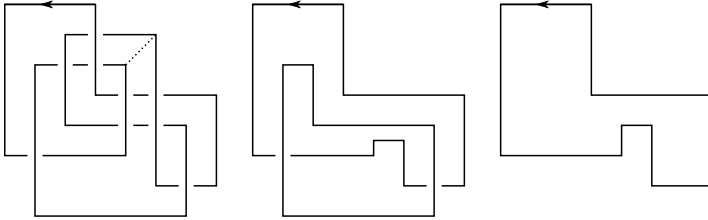

Figure 3: Inserting a Lagrangian saddle [13] along the dotted line and then capping off a Legendrian unknot to build a Lagrangian concordance from U_- to a Legendrian $m(8_{20})$, shown here in reverse.

representative C of $m(5_2)$ with $tb(C) = \overline{tb}(m(5_2)) = 1$ to a Legendrian representative K of $m(11n_{71})$ with $tb(K) = \overline{tb}(m(11n_{71})) = 0$ and $r(K) = -1$. The knot $m(5_2)$ has smooth slice genus $g_s = 1$, and $tb(C) = 2g_s(C) - 1$, so $\mathcal{L}(C) \neq 0$ over $\mathcal{R}/2\mathcal{R}$ by Corollary 3.16. Theorem 3.7 then implies that $\mathcal{L}(C_-) \neq 0$ over $\mathcal{R}/2\mathcal{R}$. We may therefore conclude that $\mathcal{L}(K) \neq 0$ over $\mathcal{R}/2\mathcal{R}$, by Theorem 1.2.

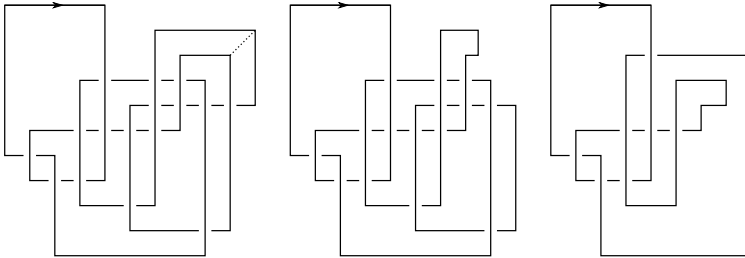

Figure 4: A Lagrangian concordance from a negatively stabilized Legendrian $m(5_2)$ to a Legendrian $m(11n_{71})$, shown in reverse.

Remark 5.3. It is worth noting that the strategies used in the two examples above to deduce nonvanishing results for \mathcal{L} cannot be used to deduce the analogous nonvanishing of Legendrian contact homology (LCH) for these Legendrian representatives of $m(8_{20})$ and $m(11n_{71})$: although LCH behaves naturally with respect to Lagrangian concordance [13], it vanishes for stabilized knots [8]. By this we mean that if K is a stabilized Legendrian knot, then the Legendrian contact homology DGA $\mathcal{A}(K)$ associated to K contains an element x such that $\partial x = 1$, which causes $\mathcal{A}(K)$ to be equivalent to the trivial DGA.

On the other hand, LCH can be used to show that the Lagrangian concordances described in these examples are nonreversible: if there were a concordance from any of these K to the respective stabilized knot S , then by [13] there would be a morphism $f : \mathcal{A}(S) \rightarrow \mathcal{A}(K)$ between their respective DGAs. Since S is stabilized, there exists an element $x \in \mathcal{A}(S)$ such that $\partial x = 1$. But since f is a DGA morphism it both is a chain map, so that $\partial(f(x)) = f(\partial x) = f(1)$, and an algebra homomorphism, so $f(1) = 1$; thus the element $y = f(x)$ of $\mathcal{A}(K)$ satisfies $\partial y = 1$, and so $\mathcal{A}(K)$ is trivial. Each K in the examples above achieves the Kauffman bound on tb , so $\mathcal{A}(K)$ admits an ungraded augmentation [41] (i.e. a chain map $(\mathcal{A}(K), \partial) \rightarrow (\mathbb{Z}/2\mathbb{Z}, 0)$ which is also an algebra morphism) and is thus necessarily nontrivial.

The first examples of nonreversible Lagrangian concordances were found by Chantraine in [7]. Our examples above provide new instances of this phenomenon. Given a nonreversible Lagrangian concordance, one can find infinitely many distinct such concordances by connect summing. Below, we provide the first infinite family of nonreversible Lagrangian concordances between *prime* knots. These examples also indicate that results in LCH may sometimes (but not always, as shown above) provide more information than our results for \mathcal{L} , cf. Remark 5.5. We compare the two here because to the best of our knowledge, LCH is the only non-classical Legendrian invariant other than \mathcal{L} and the ℓ_g of [43] which is known to behave naturally under Lagrangian concordance.

Example 5.4. Figure 5 shows the first four members K_1, K_2, K_3, K_4 of an infinite family of Legendrian knots, where K_n is a Legendrian representative the pretzel knot $P(n, 3, -3)$. It is straightforward to compute that $tb(K_n) = -(n + 4)$, and that $r(K_n)$ is 0 for odd n and ± 1 , depending on a choice of orientation, for even n .

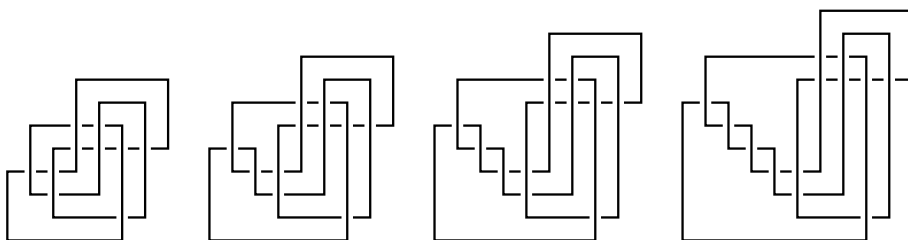

Figure 5: A family of Legendrian pretzel knots.

For each n , there is a Lagrangian concordance from a Legendrian unknot U_n to K_n , as illustrated in Figure 6 for $n = 4$. Note that $\mathcal{L}(U_n) = 0$ by Theorem 3.7 since U_n is a positive stabilization, so we cannot use Theorem 1.2 to determine whether $\mathcal{L}(K_n)$ vanishes. On the other hand, each K_n admits an ungraded normal ruling, shown in Figure 7 for $n = 4$, which implies that the Legendrian contact homology $\mathcal{A}(K_n)$ admits an ungraded augmentation [18]. Thus, $\mathcal{A}(K_n)$ is nonvanishing. Since $\mathcal{A}(U_n)$ is trivial but $\mathcal{A}(K_n)$ is not, it follows that the Lagrangian concordance from U_n to K_n is nonreversible for each n .

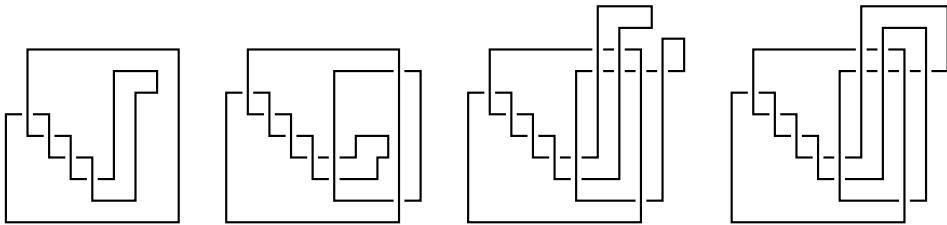

Figure 6: A Lagrangian concordance from U_4 to K_4 , built by inserting a Legendrian unknot filled with a Lagrangian cap, performing a Legendrian isotopy, and then using a Lagrangian saddle to surger two cusps together.

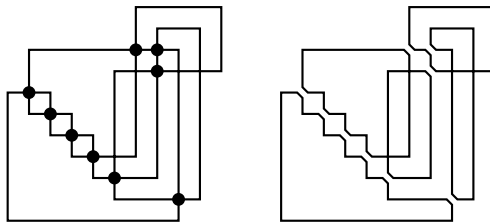

Figure 7: An ungraded normal ruling of K_4 .

Remark 5.5. We expect that $\mathcal{L}(K_n) = 0$ for all n . Indeed, each K_n has thin Khovanov homology [44]. Hence, by a well-known conjecture (cf. [1, Conjecture 1.3] and [40]), it should have thin knot Floer homology as well (and does for n odd, as computed in [38]). Ng, Ozsváth and Thurston showed in [36] that the GRID invariant [39] of an HFK -thin Legendrian knot with $tb - r < 2\tau - 1$ vanishes. This inequality holds for K_n since K_n is slice. In [4] we identify $\mathcal{L}(K_n)$ with the GRID invariant, so it follows for odd n (and should follow for even n) that $\mathcal{L}(K_n) = 0$ as well.

References

- [1] J. A. Baldwin and A. S. Levine, *A combinatorial spanning tree model for knot Floer homology*, Adv. Math. **231** (2012), no. 3-4, 1886–1939.
- [2] J. A. Baldwin and S. Sivek, *Naturality in sutured monopole and instanton homology*, J. Differential Geom. **100** (2015), no. 3, 395–480.
- [3] J. A. Baldwin and S. Sivek, *A contact invariant in sutured monopole homology*, Forum Math. Sigma **4** (2016) e12, 82.
- [4] J. A. Baldwin and S. Sivek, *On the equivalence of contact invariants in sutured Floer homology theories* (2016). [arXiv:1601.04973](https://arxiv.org/abs/1601.04973).
- [5] J. A. Baldwin, D. S. Vela-Vick, and V. Vértesi, *On the equivalence of Legendrian and transverse invariants in knot Floer homology*, Geom. Topol. **17** (2013), 925–974.
- [6] B. Chantraine, *Lagrangian concordance of Legendrian knots*, Algebr. Geom. Topol. **10** (2010), no. 1, 63–85.
- [7] B. Chantraine, *Lagrangian concordance is not a symmetric relation*, Quantum Topol. **6** (2015), no. 3, 451–474.
- [8] Y. Chekanov, *Differential algebra of Legendrian links*, Invent. Math. **150** (2002), no. 3, 441–483.
- [9] V. Colin, P. Ghiggini, and K. Honda, *The equivalence of Heegaard Floer homology and embedded contact homology III: from hat to plus*, (2012). [arXiv:math.SG/1208.1526](https://arxiv.org/abs/math/1208.1526).
- [10] V. Colin, P. Ghiggini, and K. Honda, *The equivalence of Heegaard Floer homology and embedded contact homology via open book decompositions I*, (2012). [arXiv:math.SG/1208.1074](https://arxiv.org/abs/math/1208.1074).
- [11] V. Colin, P. Ghiggini, and K. Honda, *The equivalence of Heegaard Floer homology and embedded contact homology via open book decompositions II*, (2012). [arXiv:math.SG/1208.1077](https://arxiv.org/abs/math/1208.1077).
- [12] T. Ekholm, J. Etnyre, L. Ng, and M. Sullivan, *Filtrations on the knot contact homology of transverse knots*, Math. Ann. **355** (2013), no. 4, 1561–1591.
- [13] T. Ekholm, K. Honda, and T. Kálmán, *Legendrian knots and exact Lagrangian cobordisms*, J. Eur. Math. Soc. (JEMS) **18** (2016), no. 11, 2627–2689.

- [14] Y. Eliashberg, *On symplectic manifolds with some contact properties*, J. Differential Geom. **33** (1991), no. 1, 233–238.
- [15] Y. Eliashberg, *Invariants in contact topology*, in: Proceedings of the International Congress of Mathematicians, Vol. II (Berlin, 1998), Extra Vol. II, 327–338 (1998).
- [16] J. Epstein, D. Fuchs, and M. Meyer, *Chekanov-Eliashberg invariants and transverse approximations of Legendrian knots*, Pac. J. Math. **201** (2001), no. 1, 89–106.
- [17] J. B. Etnyre, *Legendrian and transversal knots*, in: Handbook of knot theory, 105–185, Elsevier B. V., Amsterdam (2005).
- [18] D. Fuchs, *Chekanov-Eliashberg invariant of Legendrian knots: existence of augmentations*, J. Geom. Phys. **47** (2003), no. 1, 43–65.
- [19] K. Honda, *On the classification of tight contact structures, I*, Geom. Topol. **4** (2000) 309–368.
- [20] K. Honda, W. H. Kazez, and G. Matić, *The contact invariant in sutured Floer homology*, Invent. Math. **176** (2009), no. 3, 637–676.
- [21] M. Hutchings and C. H. Taubes, *Proof of the Arnold chord conjecture in three dimensions, II*, Geom. Topol. **17** (2013), no. 5, 2601–2688.
- [22] A. Juhász, *Cobordisms of sutured manifolds and the functoriality of link Floer homology*, Adv. Math. **299** (2016), 940–1038.
- [23] A. Juhász, D. P. Thurston, and I. Zemke, *Naturality and mapping class groups in Heegaard Floer homology*, (2012). [arXiv:math.GT/1210.4996](https://arxiv.org/abs/math/1210.4996).
- [24] P. Kronheimer and T. Mrowka, *Monopoles and contact structures*, Invent. Math. **130** (1997) 209–255.
- [25] P. Kronheimer and T. Mrowka, *Knots, sutures, and excision*, J. Differential Geom. **84** (2010), no. 2, 301–364.
- [26] P. Kronheimer, T. Mrowka, P. Ozsváth, and Z. Szabó, *Monopoles and lens space surgeries*, Ann. Math. **165** (2007), no. 2, 457–546.
- [27] C. Kutluhan, Y.-J. Lee, and C. H. Taubes, *HF = HM I: Heegaard Floer homology and Seiberg-Witten Floer homology*, (2010). [arXiv:math.SG/1007.1979](https://arxiv.org/abs/math/1007.1979).

- [28] C. Kutluhan, Y.-J. Lee, and C. H. Taubes, *HF = HM II: Reeb orbits and holomorphic curves for the ech/Heegaard-Floer correspondence*, (2010). [arXiv:math.SG/1008.1595](#).
- [29] C. Kutluhan, Y.-J. Lee, and C. H. Taubes, *HF = HM III: Holomorphic curves and the differential for the ech/Heegaard-Floer correspondence*, (2010). [arXiv:math.SG/1010.3456](#).
- [30] C. Kutluhan, Y.-J. Lee, and C. H. Taubes, *HF = HM IV: The Seiberg-Witten Floer homology and ech correspondence*, (2011). [arXiv:math.GT/1107.2297](#).
- [31] C. Kutluhan, Y.-J. Lee, and C. H. Taubes, *HF = HM V: Seiberg-Witten Floer homology and handle additions*, (2012). [arXiv:math.GT/1204.0115](#).
- [32] Y. Lekili, *Heegaard-Floer homology of broken fibrations over the circle*, *Adv. Math.* **244** (2013), 268–302.
- [33] P. Lisca, P. Ozsváth, A. I. Stipsicz, and Z. Szabó, *Heegaard Floer invariants of Legendrian knots in contact three-manifolds*, *J. Eur. Math. Soc. (JEMS)* **11** (2009), no. 6, 1307–1363.
- [34] P. Lisca and A. I. Stipsicz, *Ozsváth-Szabó invariants and tight contact three-manifolds. I*, *Geom. Topol.* **8** (2004), 925–945 (electronic).
- [35] L. Ng, *Combinatorial knot contact homology and transverse knots*, *Adv. Math.* **227** (2011), no. 6, 2189–2219.
- [36] L. Ng, P. Ozsváth, and D. Thurston, *Transverse knots distinguished by knot Floer homology*, *J. Symp. Geom.* **6** (2008), no. 4, 461–490.
- [37] P. Ozsváth and A. I. Stipsicz, *Contact surgeries and the transverse invariant in knot Floer homology*, *J. Inst. Math. Jussieu* **9** (2010), no. 3, 601–632.
- [38] P. Ozsváth and Z. Szabó, *Knot Floer homology, genus bounds, and mutation*, *Topology and its Applications* **141** (2004) 59–85.
- [39] P. Ozsváth, Z. Szabó, and D. Thurston, *Legendrian knots, transverse knots, and combinatorial Floer homology*, *Geom. Topol.* **12** (2008), 941–980.
- [40] J. Rasmussen, *Knot polynomials and knot homologies*, *Geometry and Topology of Manifolds* **47** (2005), 261–280.

- [41] D. Rutherford, *Thurston-Bennequin number, Kauffman polynomial, and ruling invariants of a Legendrian link: the Fuchs conjecture and beyond*, Int. Math. Res. Not. (2006) Art. ID 78591, 15.
- [42] B. Sahamie, *Dehn twists in Heegaard Floer homology*, Algebr. Geom. Topol. **10** (2010), no. 1, 465–524.
- [43] S. Sivek, *Monopole Floer homology and Legendrian knots*, Geom. Topol. **16** (2012), 751–779.
- [44] L. Starkston, *The Khovanov homology of $(p, -p, q)$ pretzel knots*, J. Knot Theory Ramifications **21** (2012), no. 5, 1250056, 14.
- [45] A. I. Stipsicz and V. Vértesi, *On invariants for Legendrian knots*, Pacific J. Math. **239** (2009), no. 1, 157–177.
- [46] C. H. Taubes, *Embedded contact homology and Seiberg-Witten Floer cohomology, I*, Geom. Topol. **14** (2010), 2497–2581.
- [47] C. H. Taubes, *Embedded contact homology and Seiberg-Witten Floer cohomology, II*, Geom. Topol. **14** (2010), 2583–2720.
- [48] C. H. Taubes, *Embedded contact homology and Seiberg-Witten Floer cohomology, III*, Geom. Topol. **14** (2010), 2721–2817.
- [49] C. H. Taubes, *Embedded contact homology and Seiberg-Witten Floer cohomology, IV*, Geom. Topol. **14** (2010), 2819–2960.
- [50] C. H. Taubes, *Embedded contact homology and Seiberg-Witten Floer cohomology, V*, Geom. Topol. **14** (2010), 2961–3000.

DEPARTMENT OF MATHEMATICS, BOSTON COLLEGE
MALONEY HALL, FIFTH FLOOR, BOSTON COLLEGE
CHESTNUT HILL, MA 02467-3806, USA
E-mail address: john.baldwin@bc.edu

DEPARTMENT OF MATHEMATICS, IMPERIAL COLLEGE LONDON
180 QUEEN'S GATE, LONDON SW7 2AZ, UNITED KINGDOM
E-mail address: s.sivek@imperial.ac.uk

RECEIVED APRIL 13, 2015

ACCEPTED OCTOBER 28, 2015