The hidden geometry in Vermeer's “The Art of Painting”*

by Gerhard Gutruf[†] and Hellmuth Stachel[‡]

This Computer-aided analysis of the geometry in VERMEER's main work “*The Art of Painting*” has two objectives: On the one hand we want to disclose some of VERMEER's hidden laws of composition. On the other hand we look for arguments contra Ph. STEADMAN's theory that a camera obscura was used for producing a geometrically correct perspective. Therefore an analytic reconstruction of the perspective was carried out and explained, under which assumptions a reconstruction of the displayed objects is possible. To avoid any misunderstanding, the reason for exposing geometrical flaws in the perspective is not pedantically doctrinaire but shall demonstrate that for VERMEER the laws of composition and artistic intuition stand much higher than just copying a camera-obscura depiction.

Key Words: Vermeer, perspective, reconstruction, camera obscura

MSC 2010: 51N05

Preliminary Statement

This survey concerning VERMEER's “*The Art of Painting*” does not aim to deconstruct the myth of

* © 2010 Helderermann Verlag. Reprinted from the *Journal for Geometry and Graphics*, vol. 14, no. 2, 186–202, Helderermann Verlag, 2010. Used with permission. Special thanks to the authors and the *Journal for Geometry and Graphics*.

[†] Hamburgerstraße 11/26, A 1050 Vienna, Austria

E-mail: gutruf.art@aon.at

Web page: <http://www.gutruf.at>

[‡] Institute of Discrete Mathematics and Geometry, Vienna University of Technology, Wiedner Hauptstr. 8–10/104, A-1040 Vienna, Austria

E-mail: stachel@dmg.tuwien.ac.at

this major work of European art. The intention is to demonstrate — with the help of precise mathematical and geometrical methods — that the picture-composition is not an imitation of a stage-like scene. The picture suggests a natural reality but its logic underlies that of VERMEER's exactly defined image area.

1. Introduction

Johannes VERMEER VAN DELFT painted his most important picture “*The Art of Painting*” in the years 1666/1668. Today it is one of the main attractions in the permanent collection of the Kunsthistorisches Museum Vienna, where a special VERMEER exhibition took place from January to April 2010 [2]. An inspection of this masterpiece reveals that it communicates in painted form a wide spectrum of knowledge referring to the art of painting:

At the first glance one can see the famous motive of the curtain on the left-hand side. Something mysterious is revealed in front of our eyes — although we cannot express absolute truth even after closer inspection and research. Therefore we take it for granted that the central concern of the artist was not the depicted scene but the meaning behind it and the intention to follow certain laws of composition.

It was our ambition to know more about the nature of a great masterpiece and to discover some of VERMEER's tricks and secrets by a detailed analysis based on computer-aided methods. Another reason for reconstructing the perspective in VERMEER's painting is to find arguments contra Philip STEADMAN's theory [7] that a camera obscura was used for producing a geometrically correct construction (see also [3]).



Figure 1. Johannes Vermeer: “De Schilderconst” [“The Art of Painting”] © Kunsthistorisches Museum Wien

In fact, the perspective of the interior is rather simple. Figure 2 shows what is needed to let a quadrangular grid (blue) correspond to the perspective image of the tiled floor (red) in a central collineation. However, important vanishing points are far outside the image area.

There is an alternative method, which already has been used by artists of the Italian renaissance: Fig. 3 reveals that only two equidistant scales are necessary to construct the perspective — thus being independent of unattainable vanishing points. Point V is an arbitrary point on the horizon h . Most probably VERMEER used this method since a deformation was detected recently (note [9, p. 199]) on the original canvas at the intersection between the horizon h and the right borderline. This point is not the vanishing point of the stool as conjectured in [9] but a reasonable choice for the vanishing point V (see Fig. 3) in order to achieve high precision.

Once the perspective of the tiled floor is finished, the images of the different objects can be constructed in a standard way by protracting altitudes. Hence, there should be no technical reason for VERMEER to use a camera obscura for obtaining the outlines of the perspective.

Moreover, significant elements of the composition withdraw themselves — by overlapping or veil-

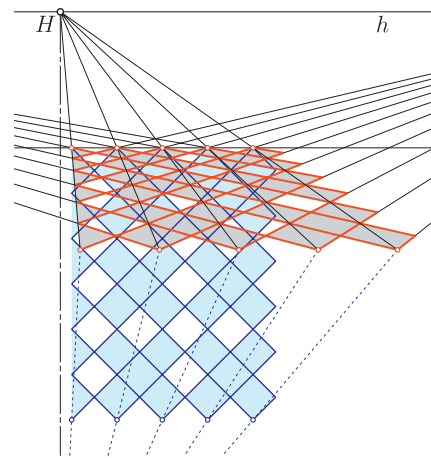

Figure 2. Drawing a perspective using a central collineation

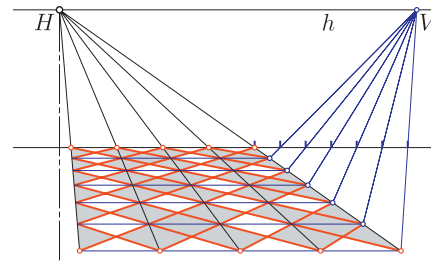

Figure 3. Construction based on two equidistant scales

ing — from a precise and uniform concept for the central perspective construction. Therefore not all objects in the scene need to be equally scaled. E.g., the painter’s stool seems to be displayed in a larger scale than the two chairs. The scale for the wallmap is still smaller (compare Table 1 on page 34).

Graphical standard methods for the reconstruction of the underlying single perspective fail. We must note (Fig. 4, left) that lines, which should pass through the central vanishing point H , are far from concurrent. Even when H is determined as the fourth harmonic conjugate to selected triples of tile-vertices, the results are rather scattered. In the same way, the method shown in Fig. 3 gives no unique result for the vanishing point $V \in h$ (Fig. 4, right). This means that graphical methods only yield rough estimates for the central vanishing point H and the horizon h ; however, their precision is crucial for that of the whole reconstruction.

Therefore in this research computer-aided *analytic* reconstruction was used. In this way different geometric data can be combined and used for a least square fit in order to obtain the most probable dimensions of the depicted objects. In addition, the analytic method offers the possibility to vary parameters like



Figure 4. The graphical method fails because of the scattered lines. Where to choose the central vanishing point H and the horizon h ?

the height of the table or the size of the tiles quite easily. This enables to discover “faults” in VERMEER’s *suggestion of reality* — in contrast to an *imitation of reality* by using a camera obscura.

In Section 3 it is explained how the analytic reconstruction can be carried out. In Section 4 we focus on the depicted objects and list the assumptions which were necessary to recover shape and position of the depicted objects. We continue with a summary of arguments against the camera-obscura theory in Section 5. Finally, Sections 6 and 7 reveal that for VERMEER the balance between the depicted objects in the painting turns out to be more decisive than following the exact rules of perspective.

It should be mentioned that D. LORDICK did a similar task in [4]: He reconstructed the perspective in VERMEER’s painting “*Girl Reading a Letter at an Open Window*”. Also in this case several assumptions were necessary for recovering data from one single perspective. By the use of dynamic geometry software with moving data sliders LORDICK could vary different parameters in order to obtain an optimal fit. This reconstruction was part of an educational project in Dresden/Germany with the goal to present the painting together with a corresponding life-sized scene.

2. Analytic Reconstruction

Our reconstruction is based on several assumptions.

Assumption 1. VERMEER’s *painting shows a photo-like perspective with an image plane parallel to the back-wall of the depicted room.*

2.1 Mapping Equations

We start using particular coordinate systems (see Fig. 5): The *camera frame* defines the 3D coordinates

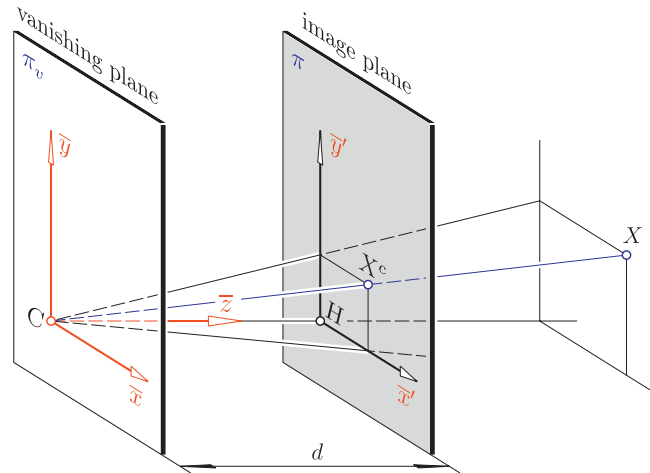

Figure 5. Standard coordinate frames

$(\bar{x}, \bar{y}, \bar{z})$: This frame has its origin at the *projection center* C , and the \bar{z} -axis as *central ray* perpendicular to the image plane. The 2D coordinates (\bar{x}', \bar{y}') in the image plane are centered at the *central vanishing point* H , the intersection point with the central ray.

Then the *central projection* $X \rightarrow X^c$ obeys in matrix form the equations (see, e.g., [6])

$$(1) \quad \begin{pmatrix} \bar{x}' \\ \bar{y}' \end{pmatrix} = \frac{d}{\bar{z}} \begin{pmatrix} \bar{x} \\ \bar{y} \end{pmatrix} \quad \text{with } d = \overline{CH}.$$

Now we adjust our *world coordinates* to the depicted scene (see Fig. 6): The back wall is specified as the yz -plane and it serves also as image plane. The y -axis is horizontal. The x -axis contains diagonals of the most-left black tiles, which are mainly hidden under the table and the front chair; only the most-right vertices of these tiles are visible.

At the beginning we choose half of the diagonal length of the tiles as *unit length*. Hence the vertices

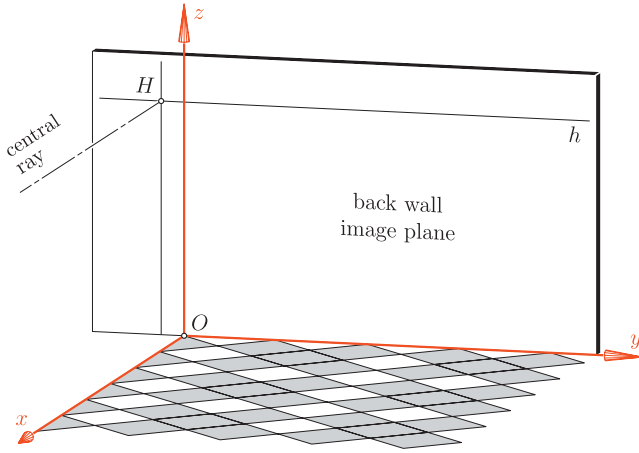

Figure 6. World coordinates in the setting

of the tiles have positive integers as world coordinates. The following transformation equations hold between our adjusted world coordinates and the camera frame:

$$\begin{pmatrix} \bar{x} \\ \bar{y} \\ \bar{z} \end{pmatrix} = \begin{pmatrix} -y_H \\ -z_H \\ d \end{pmatrix} + \begin{pmatrix} 0 & 1 & 0 \\ 0 & 0 & 1 \\ -1 & 0 & 0 \end{pmatrix} \begin{pmatrix} x \\ y \\ z \end{pmatrix}$$

Here $(0, y_H, z_H)$ are the *world coordinates* of H , and (d, y_H, z_H) those of the center C .

Since the image plane has been fixed in space, we must admit scaling factors for the image. We use factors σ_x, σ_y between the virtual image in the back-wall and the underlying painting, one in x - and one in y -direction. Furthermore, we translate the original standard coordinates. For our new image coordinates (x', y') the origin lies in the left bottom-corner of the painting. When (x'_H, y'_H) denote the *image coordinates* of the central vanishing point H , we then have the coordinate transformation

$$\begin{aligned} x' &= x'_H + \sigma_x \bar{x}' \\ y' &= y'_H + \sigma_y \bar{y}' \end{aligned}$$

Thus we end up with the *mapping equations*

$$(2) \quad \begin{aligned} x' &= x'_H + d \sigma_x \frac{-y_H + y}{d - x} \\ y' &= y'_H + d \sigma_y \frac{-z_H + z}{d - x} \end{aligned}$$

of our assumed perspective. There are seven unknowns included, d, y_H, z_H as *exterior parameters* and $\sigma_x, \sigma_y, x'_H, y'_H$ as *interior parameters* of the perspective.

2.2 Reconstruction by a Least Square Fit

Our reconstruction of VERMEER's masterpiece is based on a photograph of size 21.5×18.0 cm of the

original painting. We scanned this photo and converted it into PostScript. Then we determined the coordinates of image points with the option "Measure" of GSview. The size of the digital image is 1710.1×1441.6 pt. The original painting is of size 120×100 cm so that 1 pt in our scanned photo corresponds to about 0.07 cm original size. Off note is that the ratio 6 : 5 is preferred by VERMEER; even the depicted canvas poised on the eagle seems to have the same ratio.

There are 18 vertices X_1, \dots, X_{18} of tiles visible in the painting. Their (integer) world coordinates $(x_i, y_i, 0)$ (Fig. 6) and their image coordinates (x'_i, y'_i) are available. Hence, each of these grid points leads to two equations

$$(3) \quad \begin{aligned} x'_i u_1 - y_i u_2 + x_i u_3 - u_4 &= x_i x'_i \\ y'_i u_1 - z_i u_5 + x_i u_6 - u_7 &= x_i y'_i. \end{aligned}$$

They are linear in the 7 unknowns u_1, \dots, u_7 , where

$$(4) \quad \begin{aligned} u_1 &= d, & u_2 &= d \sigma_x, & u_3 &= \sigma_x x'_H, & u_4 &= d \sigma_x (x'_H - y_H), \\ u_5 &= d \sigma_y, & u_6 &= \sigma_y y'_H, & u_7 &= d \sigma_y (y'_H - z_H). \end{aligned}$$

These 36 inhomogeneous equations define an overdetermined system¹ — in matrix form expressible by $\mathbf{A} \cdot \mathbf{u} = \mathbf{b}$. We know that in the sense of a least square fit the optimal solution for the unknowns u_1, \dots, u_7 solves the system of *normal equations*

$$(5) \quad (\mathbf{A}^\top \cdot \mathbf{A}) \cdot \mathbf{u} = \mathbf{A}^\top \cdot \mathbf{b}.$$

In terms of the Moore-Penrose pseudoinverse \mathbf{A}^+ of \mathbf{A} we can express this optimal solution also by $\tilde{\mathbf{u}} = \mathbf{A}^+ \cdot \mathbf{b}$. From these optimal $\tilde{u}_1, \dots, \tilde{u}_7$ we compute step by step the external and internal parameters of the given perspective.

2.3 Discussion of the Numerical Results

The result of our procedure reads as follows: With respect to the painting in original size, the central vanishing point H has the coordinates **(35.9, 55.3)** in cm. A deformation in this area in form of a hole, which can be seen as a technical construction aid, was detected in 1949 by HULTÉN [1, p. 199, footnote 4]. Fig. 7 shows point H and the horizon h . In fact, there are only a few plausible explanations for the placement of the horizon h in VERMEER's paintings (note, e.g., [8, p. 151]). Our comment is as follows (compare Fig. 14):

¹ We obtain a system equivalent to (3) when the equations are multiplied with arbitrary factors, for example, with $1/x_i$. This acts like putting weights on the equations and changes the solution. Numerical tests with reasonable weights showed that the obtained data can vary within about $\pm 1.0\%$

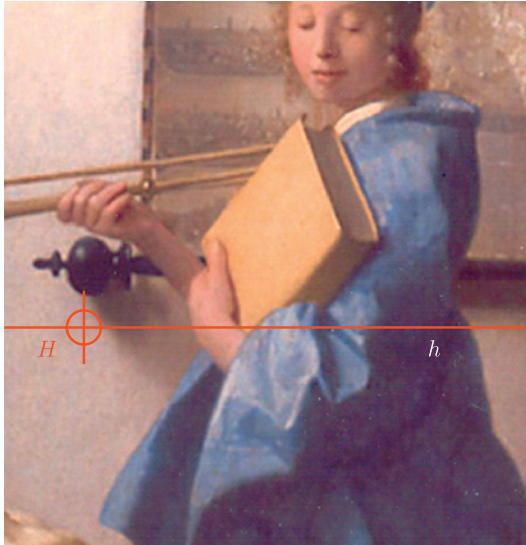

Figure 7. Computed position of the central vanishing point

- The horizon h , which is relevant for the depiction of the room, passes through the upper part of the painter's body on the level of his heart as well as through his hand which is supported by the maulstick. The brush is depicted vertically and connects the upper part of the painting with the lower one.
- On the other hand, the depicted painter's horizon, which passes through his eyes, traverses the lower part of the depicted map frame thus connecting the painter with the model. By the way, VERMEER's signature is placed exactly at this level (note [2, p. 196]).

It is remarkable as well as sophisticated that the horizon of the painter appears higher than that of the beholder of the scene. The highest horizon is that of the model Clio. The girl gazes down into the open sketchbook.

In our result the distance d between the center C of projection and the image plane (in original size) is **173.5 cm** (note Footnote 1). Therefore the two vanishing points of the sides of the tiles are placed on the horizon h about 140 cm left from the left edge and 110 cm right of the right edge of the painting, respectively. With these numerical results the statement [9, p. 199] cannot be verified with sufficient precision that the golden ratio shows up at these vanishing points together with H and the border lines of the painting.

When the mapping equations with the optimal parameters are applied to the exact world coordinates of the grid points, we obtain new positions for the 18 vertices (see dashed lines in Fig. 8). With respect to the original size 120×100 cm the mean

errors in horizontal x - and vertical y -direction are 0.11 cm and 0.08 cm, respectively. The maximum error in x -direction is 0.30 cm and that in y -direction 0.24 cm; hence the precision of the depicted tiles is quite remarkable. The grid points with these maximum errors are marked in Fig. 8 by red rings with 1 cm diameter. The computed points are the respective centers of these rings.

3. Reconstruction of the Scene

After having determined the optimal mapping equations we can proceed by reconstructing the depicted objects as far as possible. Already a rough inspection reveals that without additional assumptions many objects cannot be reconstructed because their relative position to the floor is often hidden. This is characteristic of VERMEER and the reason why he is sometimes called "*Sphinx of Delft*". None of the shadows can be used for recovering information. They are never constructed but serve for contrast effects only.

3.1 The Chairs

We recover the placement of the front chair by use of

Assumption 2. *The two depicted chairs, one in front, the other close to the back-wall, are equal models and therefore of the same size.*

It turns out that the reconstructions of both chairs look rather distorted. The corrected edges of the front seat can be seen as dashed lines in Fig. 10.

3.2 The Stool

The points where the legs of the stool meet the tiled floor form a rather precise rectangle. However, the reconstruction of the top gives a rather distorted rectangle (Fig. 11). An inspection of VERMEER's painting reveals that the image of the stool is closer to an axonometric view than to a perspective because the front edge of the top rectangle is almost parallel to the line connecting the bases of the two front legs as well as to the crossbar between (note Fig. 9). This might be caused by the fact that the corresponding vanishing point is about 5.4 m left of the left border line of the painting, or it was VERMEER's intention to mix central and parallel projection in his painting. Or — as pointed out in Section 6 — the "laws of the image area" had priority.

We can recover the height of the seat by

Assumption 3. *The seat of the stool is positioned symmetrically over the legs.*



Figure 8. The precision of the displayed tiles is remarkable



Figure 9. Recovering the chairs



Figure 10. Missing corner of a tile and misplaced seat of the stool

As shown in Fig. 11, when varying the height of the stool the position of the seating area varies. The different heights listed in Fig. 11 correspond to a tile length of 27.5 cm (see also Table 1). Assumption 3 leads to a good estimate of the height.

3.3 The Table with the Still Life

The points where the legs of the table meet the floor are not visible. Since also the exact height of the table is unknown, we cannot figure out the exact position. We only know that there must be sufficient space between the table and the back-wall for Clio and in front between the chair and the table for the curtain hanging down.

Another part of the mysterious masterpiece shall be mentioned here: The opened sketch-book, which is partly protruding beyond the table, seems to touch the artist. When compared to the original painting, it is not certain that the harem pants are overlapping the parchment edge or vice versa, though it is evident in the top view (Figs. 12 and 13) that the table and the parchment are clearly situated in front of the sitting artist. A spot of light set amidst hinders any conclusion drawn from the painting itself. The study in the

sketch-book (inspired by the muse Clio?) and the executing artist are directly “spot-welded” on the image area.

3.4 The Most Probable Size of Tiles

When comparing the size of the chairs and the stool, the seat of the stool is larger than that of the chairs. This indicates already that the scale of the stool with the painter is slightly greater than that of other depicted objects.

Despite all of our assumptions, we are not able to figure out the true size of the depicted objects, but we can express these relative to the length of the tiles. Ph. STEADMAN has good reason for the estimate 29.5 cm (note also the tables in [7, pp. 171–176] or [2, p. 164]), but also an estimate of 27.5 cm gives reasonable results, and there is an argument for this length: VERMEER’s painting “*Lady standing at a virginal*” shows a tiled floor and additionally small decorated tiles on the wall. The length of three wall tiles seems to equal the diagonal length of one tile on the floor. The

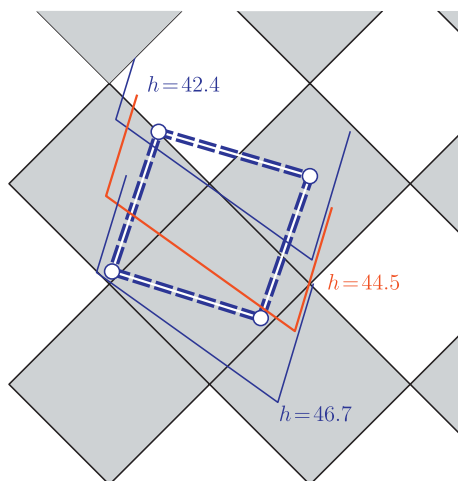

Figure 11. Recovering the seating area of the stool

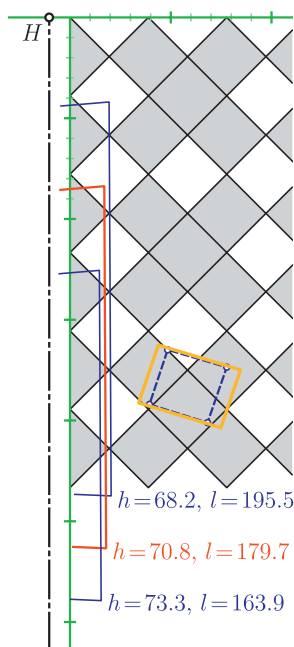

Figure 12. Recovering position and height of the table

first-named author holds such small tiles produced in Delft in the 17th century; their length is 12.7 cm, and $3 \times 12.9/\sqrt{2} = 27,4$.

The following Table 1 lists some recovered dimensions for both choices of tile-lengths. Furthermore, it offers a comparison with some confirmed original data in the last column.

4. Arguments Against the Camera-Obscura Theory

Here we summarize arguments which in the authors' opinion contradict the statement that VERMEER

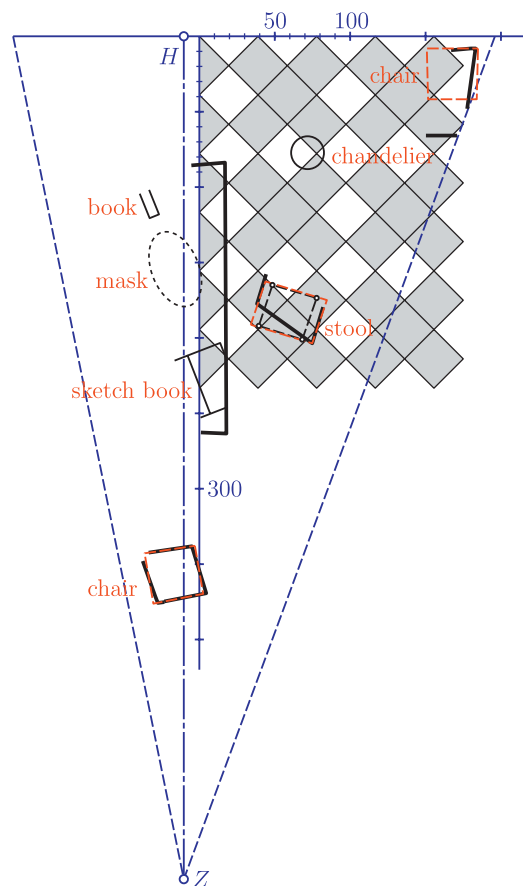

Figure 13. Top view of the depicted scene (with the corrected chairs and stool in red)

used a camera obscura for constructing the perspective drawing in "The Art of Painting".

- Primary is the argument that, for VERMEER, the sense behind the depicted scene, his allegoric allusions and the laws of composition range much higher than the demand for a geometrically exact depiction. The following sections will demonstrate how laws of composing the painting area dictated the placement of several objects. Note, for example, the missing part of a black tile right of the painter's right calf (see green lines Fig. 10): The effect of a small black area here would be disturbing.
- It can be questioned whether with the technology of the 17th century a manually or mechanically scaled camera obscura projection could reach the remarkable precision with a mean error of about ± 1 mm at the grid of tiles in VERMEER's painting. Since in this projection the central vanishing point would be in the center, the scaled projection needs to be 130×130 cm in order to include the decentral painting of size 120×100 cm. Under this assumption, what about the hole at the central vanishing point H ?

Table 1. Recovered dimensions in dependance from the length of the tiles (in cm)
(note Footnote 1 on page 30)

<i>assumed length of tiles</i>	27.5	29.5	<i>original size</i>
length of table	181.9	195.1	189-192
height of table	70.8	75.9	78-80
thickness of plate	9.3	9.9	8-10
height of stool	44.5	47.8	
width of stool	42.4	45.5	
height of chairs	48.9	52.5	47
width of chairs	31.9-33.5	34.2-35.9	
length of chairs	33.2	35.6	
height of chandelier	64.9	69.6	65
diameter of chandelier	75.7	81.2	73
height of Clío	145.0	155.0	
height of sitting painter	130.0	139.5	
size of proper map	95.6×133.5	102.6×143.2	111.64×150.3
total size of wall map	123.7×187.9	132.7×201.6	147.0×211.6

- If VERMEER had based his painting only on a camera-obscura projection, he would not have made the errors in the perspective of the stool (Fig. 9) and the front chair (Fig. 10). In particular, the stool lies rather central, so this error cannot be explained by a distortion caused by the lens.

5. Laws of the Plane

Some examples from VERMEER's painting demonstrate that the depicted objects were positioned layer above layer in order to obscure their real dimensions and to veil their stereometrical position with respect to the depicted room. In this way he has freedom to place lines according to the "laws of the plane".

5.1 Harmonical (Rational) Divisions

VERMEER often used a format with the ratio 12 : 10 for his paintings. We reveal a more logical correspondence when we uniformly subdivide the side lengths into 12 and 10 units, resp., and place a quadratic grid over the composition (Fig. 14).

- The horizontal center line touches the knob of the red cushioned painting-stick and passes through the upper edge of the painting on the easel as well as through the trumpet-holding hand of the girl.
- The vertical center line cuts through the roman number XVII which can be seen in the title of the map. This might reflect the separation of the Netherlands in 1581, when the 17 provinces were subdivided into the 7 Protestant northern provinces and the 10 Catholic provinces of Spanish Netherlands [5].



Figure 14. A quadratic grid subdividing the painting area 12 : 10

- This vertical center line also covers the border between the light and dark upper parts of the girl's blue cape, the vertical wrinkles of her skirt and the far-left visible vertex of the front-tiles.
- The last partitioning vertical line on the right hand side is a border line for the views of the vedutas on the wall-map. Furthermore, it coincides with the right border of the canvas on the easel and passes through the most-right visible vertex of the front-tiles.



Figure 15. Subdividing the painting area in the golden ratio by horizontal and vertical lines

Lines in a painting which produce major connections between several depicted objects are called “transparent lines”. They are of fundamental importance for the formal coherence of any composition.

5.2 The Golden Ratio

- When the width of the painting is subdivided in the golden ratio (Fig. 15), the left partitioning line passes exactly through the left border of the wall-map. The right partitioning vertical line passes through the front vertex of a front tile.
- Subdivision of the height defines a line which passes approximately through the upper end of the easel. The depicted painter’s right elbow rests on the lower partitioning line.
- In the depicted scene the artist appears to paint on his canvas exactly the “*central motive*”, i.e., the part enclosed by these golden partitioning lines.

5.3 The Pentagon Construction

We inscribe a regular pentagon in the circumcircle of the painting. When the highest vertex of the pentagon is chosen on the vertical center line of the painting, we notice (Fig. 16):

- The left hand diagonal passing through the top vertex indicates the inclination of the opened curtain.
- The second diagonal passing through the left bottom vertex of the pentagon coincides with the maulstick.

- The line connecting the right bottom vertex with the central vanishing point covers one edge of the table.
- The city of Delft on the map coincides with an intersection point of two diagonals. In the way, this point subdivides the horizontal diagonal segment in the golden ratio.

6. Priorities of the Painting’s Composition

Whenever the consequences of the central perspective construction come into conflict with the plane composition, great masters prefer the latter. In this sense, the relation of the depicted objects to the border lines of the picture also has priority over the laws of perspective.

- The front tiles of the floor clearly end approximately 0.3 cm above the picture border. VERMEER refrains from continuing the design towards the front.
- The shadows in the picture seem to be randomized. VERMEER used them for his compositional needs. For example, the composition of the right hand side of the picture is terminated by the dark shadow placed on the right hand side of the map as well as by the shadow in front of the chair next to the wall. The easel has no identifiable shadow associated.
- The wooden beams of the ceiling are constructed demonstratively plain. They seem to be folded inside the image plane and define the top of the picture.
- The missing corner of a black tile (Fig. 10) between the painter’s right shinbone and the cross bar of the easel shows that the distribution or light and dark had priority. Otherwise, this small black triangle would be disturbing.
- The contour lines of objects in VERMEER’s paintings are uniformly blurred “*sfumato*”-like. As a consequence, spatial distances are hard to estimate, the compositions look planar.

7. Conclusion

It was our aim to disclose some of the secrets hidden in VERMEER’s masterpiece. For this purpose we applied geometric and computer-aided methods of reconstruction. However, without a few assumptions it is not possible to recover the whole scene. Nevertheless, on the one hand the precision of the depicted tiles is remarkable. On the other hand, we notice different scales for different objects (compare in Table 1 the reconstructed dimensions with some confirmed original sizes). At several places one can

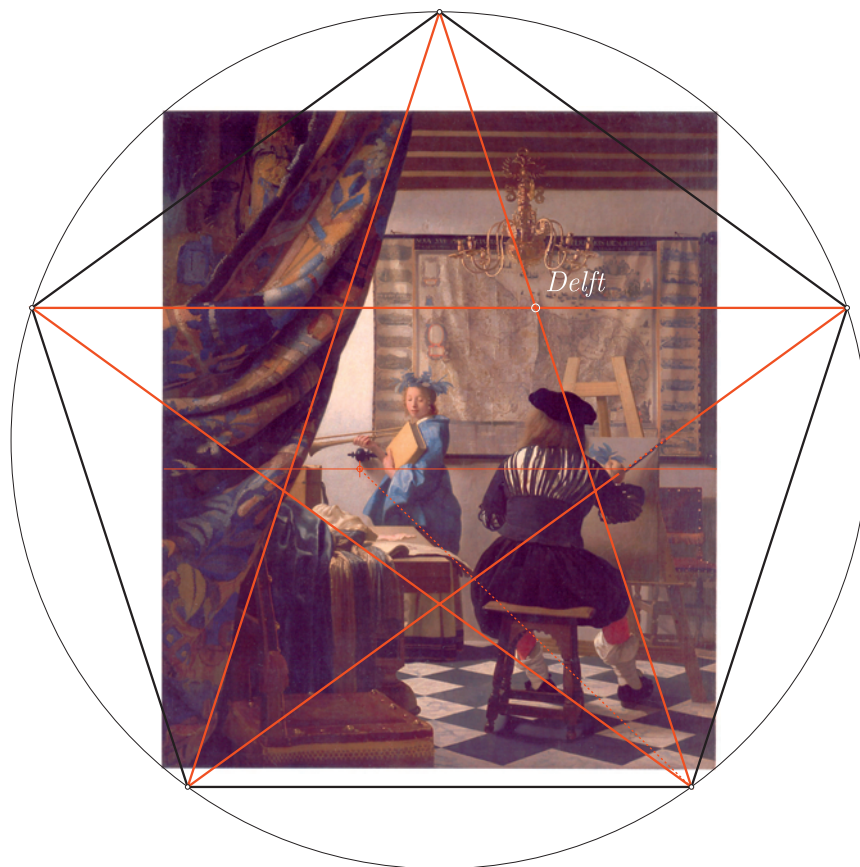

Figure 16. The painting area and its relation to a regular pentagon

observe that for VERMEER the laws of composing the area in a painting are of higher importance than a geometrically exact construction.

The discovered “flaws” in VERMEER’s painting are not at all caused by lack of knowledge of geometric rules, but they can only be understood as consequences of VERMEER’s method of composition. Hence, they are correct — even in the geometric sense.

Our observations help also to obtain a clear answer to the question of whether a camera obscura was used for the composition in “The Art of Painting”: For VERMEER it was not possible to copy something from a model (note top view in Fig. 13) which does not exist in reality because of the missing uniform scale (Table 1).

Acknowledgements

The authors thank Robert Wald, the author of [9], for his useful comments. In addition, the authors thank Prof. Helderemann for the permission to reprint this article, which was first published in the *Journal for Geometry and Graphics* 14/2, 187–201 (2010).

References

- [1] G. Gutruf: *Spotlights - Gutruf*. Vienna 1998, 65 p.
- [2] S. Haag, E. Oberthaler, S. Pénot (eds.): *Vermeer, The Art of Painting, Scrutiny of a Picture* [German with English translation]. Exhibition catalog, Residenz Verlag, Vienna 2010, ISBN 978-3-85497-171-9.
- [3] http://www.esentialvermeer.com/catalogue/art_of_painting.html, 28.12.09
- [4] D. Lordick: *Parametric Reconstruction of the Space in Vermeer’s Painting “Girl Reading a Letter at an Open Window”*. Proc. 14th ICGG, Internat. Conf. on Geometry and Graphics, Kyoto/Japan 2010, no. 173, 8 p.
- [5] H. Sedlmayr: *Epochen und Werke II*. Wien/München 1960.
- [6] H. Stachel: *Descriptive Geometry Meets Computer Vision – The Geometry of Two Images*. *J. Geometry Graphics* 10/2, 137–153 (2006).
- [7] Ph. Steadman: *Vermeer’s Camera, Uncovering the Truth behind the Masterpieces*. Oxford University Press, New York 2001.
- [8] J. Wadum: *Johannes Vermeer (1632–1675) and His Use of Perspective*. In E. Hermens (ed.): *Preprints Historical Painting Techniques, Materials, and Studio Practice*. University of Leiden 1995, Getty Publications, pp. 148–154.
- [9] R. Wald: *The Art of Painting. Observations on Approach and Technique*. In [2], Vienna 2010, pp. 312–321 [German: pp. 193–213].