

Positivity of relativistic spin network evaluations

Hendryk Pfeiffer

Perimeter Institute for Theoretical Physics,
35 King Street N, Waterloo, Ontario, N2J 2W9, Canada
and

Emmanuel College, St Andrew's Street,
Cambridge CB2 3AP, United Kingdom

hpfeiffer@perimeterinstitute.ca

Abstract

Let G be a compact Lie group. Using suitable normalization conventions, we show that the evaluation of $G \times G$ -symmetric spin networks is non-negative whenever the edges are labeled by representations of the form $V \otimes V^*$ where V is a representation of G , and the intertwiners are generalizations of the Barrett–Crane intertwiner. This includes in particular the relativistic spin networks with symmetry group $Spin(4)$ or $SO(4)$ on a large class of graphs, not restricted to the graph underlying the $10j$ -symbol. We also present a counterexample, using the finite group S_3 , to the stronger conjecture that all spin network evaluations are non-negative as long as they can be written using only group integrations and index contractions. This counterexample applies in particular to the product of five $6j$ -symbols which appears in the spin foam model of the S_3 -symmetric BF -theory on the two-complex dual to a triangulation of the sphere S^3 using five tetrahedra. We show that this product is negative real for a particular assignment of representations to the edges.

1 Introduction

Spin networks were invented by Penrose as a tool to describe the quantum geometry of space-time [1]. They feature as the kinematical states in non-perturbative Quantum Gravity [2] and play a central role in Spin Foam Models [3] of Quantum Gravity whose amplitudes are calculated by evaluating spin networks.

A spin network is a graph whose edges are labeled by representations of a suitable symmetry group G and whose vertices are labeled by compatible intertwiners (G -morphisms). A spin network is evaluated by writing down tensors for the intertwiners at the vertices and by contracting their indices as prescribed by the edges.

In the Barrett–Crane spin foam model [4] of Riemannian Quantum Gravity, the amplitudes of the path integral are defined in terms of a special type of spin networks. These are called the *relativistic spin networks*. Their symmetry group is $Spin(4) \cong SU(2) \times SU(2)$ or $SO(4)$, their edges are labeled by *balanced representations*, i.e. representations of the form $V \otimes V$ where V denotes a finite-dimensional irreducible representation of $SU(2)$, and their vertices are labeled by a special intertwiner, known as the *Barrett–Crane intertwiner*. The four-simplex amplitude of the Barrett–Crane model is given by a particular relativistic spin network, the *relativistic 10j-symbol*, whose underlying graph is the complete graph of 5 vertices.

In the course of the first explicit computations of relativistic 10j-symbols [5], it was observed that they always evaluate to non-negative real numbers, up to some signs which cancel when one calculates the product of 10j-symbols over all four-simplices of a closed manifold [6].

In the present article, we generalize the result of [6] to relativistic spin networks on a large class of graphs¹. While [6] has established the positivity of the Barrett–Crane amplitudes for the case of 10j-symbols, i.e. for five-valent vertices and therefore for a model which is defined on the two-complex dual to a triangulation, our generalization extends this result to the Barrett–Crane model defined on generic two-complexes. In addition, we present a formulation in which unnecessary signs are avoided right from the beginning and which allows us to generalize the result to $G \times G$ -symmetric spin networks whose edges are labeled by representations of the form $V \otimes V^*$ where V denotes a representation of G , and whose intertwiners are certain generalizations of the Barrett–Crane intertwiner.

¹Any subgraph of a complete graph.

The key idea of our proof is to use a canonical description for the intertwiners in terms of their integral presentation. A main technical problem in the study of spin networks is that one needs good conventions in order to define the intertwiners, *i.e.* some Clebsch–Gordan coefficients, at the vertices. For a single intertwiner, however, there is no canonical definition known. Writing down Clebsch–Gordan coefficients rather requires the choice of bases for the representation spaces, and the resulting expressions do depend on these choices.

A typical example is a three-valent vertex of an $SU(2)$ -spin network whose edges are labeled by irreducible representations. Let V_j, V_k, V_ℓ where $j, k, \ell = 0, \frac{1}{2}, 1, \dots$ denote the irreducible representations of $\dim V_j = 2j + 1$. Then the dimension of the space of compatible intertwiners is

$$\dim \text{Hom}_{SU(2)}(V_j \otimes V_k \otimes V_\ell, \mathbb{C}) = \begin{cases} 1, & \text{if } \ell = |j - k|, |j - k| + 1, \dots, j + k, \\ 0, & \text{otherwise.} \end{cases} \quad (1.1)$$

The space of intertwiners is at most one-dimensional, but this still does not fix the intertwiner. Given any choice of normalization, there will still be signs appearing when one exchanges two of the three tensor factors. This can be seen most easily in the special case $j = k = \ell = 1$ in which the one-dimensional trivial representation is contained in the totally antisymmetric subspace of $V_1 \otimes V_1 \otimes V_1$. The main difficulty of the positivity proof are these signs which one has to keep track of. The positivity proof that has been found for products of $10j$ -symbols [6] already indicates that it is necessary to consider pairs of these intertwiners, chosen carefully so that these signs cancel.

The strategy of the present article is to concentrate on canonical objects which can be defined without any choices². Already in the study of the duality transformation for non-Abelian lattice gauge theory [7, 8], it was noticed that an important role is played by a canonically defined object, the intertwiner arising from the integration over the symmetry group G acting on a tensor product of representations, equation (2.10) below, which gives rise to pairs of intertwiners, called $P^{(j)}$ in (2.13) below, whose *relative* normalization is canonically fixed. This leads automatically to the desired cancellation of signs.

The evaluated spin networks whose positivity we wish to prove, take in general values in \mathbb{C} and can be written as traces of suitable linear maps. At the technical level, the key idea of the proof is to defer the calculation of the

²Robert Oeckl conjectured that one can produce a large class of positive spin networks following this idea.

traces to a later stage and to study the linear maps instead. In fact, many of these linear maps are actually *positive*, i.e. it is not only their trace that is positive, but rather the individual summands of the trace. By making these stronger conditions explicit in the calculations, we are able to construct an infinite family of positive linear maps by induction. Their traces will then provide the evaluated spin networks and establish their positivity. The proof is elementary and purely algebraic except for the input that orthogonal projectors are positive.

Going beyond the study of relativistic spin networks, it is tempting to conjecture that all spin networks that can be written down using only group integrations and index contractions, are positive. We show by counterexample that this stronger conjecture is not true.

The present article is organized as follows. In Section 2, we review some properties of positive operators and of finite-dimensional representations of compact Lie groups. We also introduce a convenient diagrammatic language. We prove the positivity of relativistic spin networks in Section 3 and present counterexamples to the stronger conjecture in Section 4. Section 5 contains some concluding remarks.

2 Mathematical background

2.1 Positive linear operators

Basic facts about positive linear maps can be found in many textbooks. We need only properties that hold in (possibly infinite-dimensional) Hilbert spaces and refer the reader to [9] for more details and for the proofs of the following results.

Definition 2.1. Let \mathcal{H} be a Hilbert space with scalar product $\langle \cdot, \cdot \rangle$. We denote the set of bounded linear operators on \mathcal{H} by $\mathcal{L}(\mathcal{H})$. An operator $A \in \mathcal{L}(\mathcal{H})$ is called *positive* if $\langle v, Av \rangle \geq 0$ for all $v \in \mathcal{H}$. In this case, we write $A \geq 0$.

For any operator $A \in \mathcal{L}(\mathcal{H})$, we have $A^\dagger A \geq 0$. Positive linear operators have the following properties.

Lemma 2.2. Let \mathcal{H} be a Hilbert space and $A \in \mathcal{L}(\mathcal{H})$ be positive.

1. A is self-adjoint, $A = A^\dagger$,

2. There exists a unique positive $B \in \mathcal{L}(\mathcal{H})$ such that $B^2 = A$,
3. Any operator $X \in \mathcal{L}(\mathcal{H})$ for which $[A, X] = 0$, also satisfies $[B, X] = 0$.

In this article, we will construct our positive operators from orthogonal projectors.

Definition 2.3. Let \mathcal{H} be a Hilbert space. A linear operator $P \in \mathcal{L}(\mathcal{H})$ is called a *projector* if $P^2 = P$. A projector P is called *orthogonal* if $P^\dagger = P$.

We can then construct positive operators as follows.

Lemma 2.4. Let $\mathcal{H}, \mathcal{H}_1, \mathcal{H}_2$ be Hilbert spaces.

1. Any orthogonal projector $P \in \mathcal{L}(\mathcal{H})$ is positive,
2. If $A \in \mathcal{L}(\mathcal{H}_1)$ is positive, so is $A \otimes \mathbf{1}_{\mathcal{H}_2}: \mathcal{H}_1 \otimes \mathcal{H}_2 \rightarrow \mathcal{H}_1 \otimes \mathcal{H}_2$, where $\mathbf{1}_{\mathcal{H}_2}$ denotes the identity on \mathcal{H}_2 ,
3. If $D: \mathcal{H}_1 \otimes \mathcal{H}_2 \rightarrow \mathcal{H}_1 \otimes \mathcal{H}_2$ is positive and the partial trace $\text{tr}_{\mathcal{H}_2}(D): \mathcal{H}_1 \rightarrow \mathcal{H}_1$ exists, then $\text{tr}_{\mathcal{H}_2}(D) \geq 0$,
4. If $E, F \in \mathcal{L}(\mathcal{H})$ are both positive and $[E, F] = 0$, then EF is also positive.

2.2 Representations of compact Lie groups

In this paragraph, we introduce our notation for finite-dimensional representations of compact Lie groups. For more details, see, for example the textbook [10] or the introduction of [11].

Let G be a compact Lie group. We denote finite-dimensional complex vector spaces on which G is represented by V_ρ and by $\rho: G \rightarrow \text{Aut } V_\rho$ the corresponding group homomorphisms. For each representation ρ , the dual representation is denoted by ρ^* , and the dual vector space of V_ρ by V_ρ^* . The dual representation is given by $\rho^*: G \mapsto \text{Aut } V_\rho^*$, where

$$\rho^*(g): V_\rho^* \rightarrow V_\rho^*, \quad \eta \mapsto \eta \circ \rho(g^{-1}). \tag{2.1}$$

There exists a one-dimensional ‘trivial’ representation of G which is isomorphic to \mathbb{C} .

Since each finite-dimensional representation of G is equivalent to a unitary representation, we can choose G -invariant (sesquilinear) scalar products

$\langle \cdot; \cdot \rangle$ and orthonormal bases $\{e_j\}$. We can then define a bijective antilinear map $*$: $V_\rho \rightarrow V_\rho^*$ induced by the scalar product,

$$*(v) := (w \mapsto \langle v; w \rangle), \quad v \in V_\rho, \quad (2.2)$$

and construct the dual bases $\{\eta^j\}$ by $\eta^j := *(e_j)$. Identifying $(V_\rho^*)^* = V_\rho$, this yields $\langle e_j; e_k \rangle = \eta^j(e_k) = \delta_{jk}$ and furthermore induces a scalar product on V_ρ^* , namely $\langle \eta^j; \eta^k \rangle = \eta^k(e_j)$, $1 \leq j, k \leq \dim V_\rho$.

The matrix elements of the representation matrices $\rho(g)$ define complex valued functions,

$$t_{jk}^{(\rho)}: G \rightarrow \mathbb{C}, \quad g \mapsto t_{jk}^{(\rho)}(g) := \eta^j(\rho(g)e_k) = (\rho(g))_{jk}, \quad (2.3)$$

where ρ , $1 \leq j, k \leq \dim V_\rho$. They are called *representative functions* of G and form a commutative and associative unital algebra over \mathbb{C} ,

$$C_{\text{alg}}(G) := \{t_{jk}^{(\rho)}: \rho \text{ finite-dimensional representation of } G, \\ 1 \leq j, k \leq \dim V_\rho\}, \quad (2.4)$$

whose product is given by the matrix elements of the tensor product of representations,

$$(t_{jk}^{(\rho)} \cdot t_{\ell m}^{(\sigma)})(g) := t_{j\ell, km}^{(\rho \otimes \sigma)}(g), \quad (2.5)$$

where $1 \leq j, k \leq \dim V_\rho$ and $1 \leq \ell, m \leq \dim V_\sigma$. We find the following expressions involving the group unit $e \in G$,

$$t_{jk}^{(\rho)}(e) = \delta_{jk}, \quad (2.6)$$

products of group elements,

$$t_{jk}^{(\rho)}(g \cdot h) = \sum_{\ell=1}^{\dim V_\rho} t_{j\ell}^{(\rho)}(g) \cdot t_{\ell k}^{(\rho)}(h), \quad (2.7)$$

and inverse group elements,

$$t_{jk}^{(\rho)}(g^{-1}) = (\rho(g)^{-1})_{jk} = \overline{(\rho(g))_{kj}} = \overline{t_{kj}^{(\rho)}(g)}, \quad (2.8)$$

as well as,

$$t_{jk}^{(\rho)}(g^{-1}) = \eta^j(\rho(g)^{-1}e_k) = (\rho^*(g)\eta^j)(e_k) = \langle \eta^k; \rho^*(g)\eta^j \rangle = t_{kj}^{(\rho^*)}(g), \quad (2.9)$$

so that for unitary representations, the dual representation is just the conjugate. The bar denotes complex conjugation.

2.3 Diagrammatics

In the following, we introduce the basic object which contains pairs of intertwiners (or Clebsch–Gordan coefficients) which are together canonically defined.

Definition 2.5. Let G be a compact Lie group and ρ_1, \dots, ρ_r be finite-dimensional irreducible representations of G . The *Haar intertwiner* is defined by

$$T: \bigotimes_{\ell=1}^r V_{\rho_\ell} \rightarrow \bigotimes_{\ell=1}^r V_{\rho_\ell}, \quad T := \int_G \rho_1(g) \otimes \dots \otimes \rho_r(g) dg, \quad (2.10)$$

and has the matrix elements,

$$T_{m_1 m_2 \dots m_r; n_1 n_2 \dots n_r} = \int_G t_{m_1 n_1}^{(\rho_1)}(g) t_{m_2 n_2}^{(\rho_2)}(g) \dots t_{m_r n_r}^{(\rho_r)}(g) dg. \quad (2.11)$$

The following proposition shows how T gives rise to a pair of intertwiners $P^{(j)}$. It also introduces our normalizations in detail.

Proposition 2.6. Let G be a compact Lie group and ρ_1, \dots, ρ_r be finite-dimensional unitary representations of G such that their tensor product has the complete decomposition

$$V_{\rho_1} \otimes \dots \otimes V_{\rho_r} \cong V_{\tau_1} \oplus \dots \oplus V_{\tau_k}, \quad (2.12)$$

into irreducible components τ_j of which precisely $\tau_1, \dots, \tau_\ell, 0 \leq \ell \leq k$, are isomorphic to the trivial representation. Let $P^{(j)}: V_{\rho_1} \otimes \dots \otimes V_{\rho_r} \rightarrow V_{\tau_j} \subseteq V_{\rho_1} \otimes \dots \otimes V_{\rho_r}$ be the G -invariant orthogonal projectors associated with the above decomposition. Then

$$T_{m_1 m_2 \dots m_r; n_1 n_2 \dots n_r} = \sum_{j=1}^{\ell} \overline{P_{m_1 m_2 \dots m_r}^{(j)}} P_{n_1 n_2 \dots n_r}^{(j)}, \quad (2.13)$$

where

$$P_{n_1 n_2 \dots n_r}^{(j)} := \langle w^{(j)}; e_{n_1}^{(\rho_1)} \otimes e_{n_2}^{(\rho_2)} \otimes \dots \otimes e_{n_r}^{(\rho_r)} \rangle, \quad (2.14)$$

are the matrix elements of the projectors. Here $\{e_i^{(\rho_q)}\}$ denotes an orthonormal basis of V_{ρ_q} and $w^{(j)}$ a normalized vector spanning $V_{\tau_j} \subseteq V_{\rho_1} \otimes \dots \otimes V_{\rho_r}$.

Equation (2.13) shows how the canonical object T is decomposed into pairs of intertwiners $P^{(j)}$. In the Ponzano–Regge model, for example, the

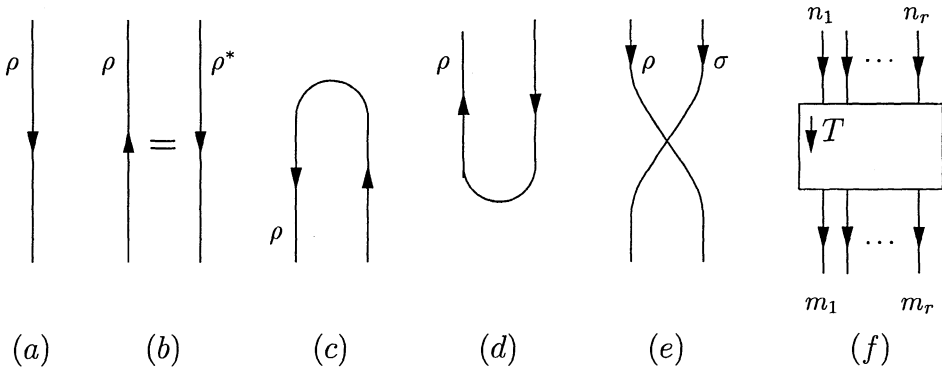

Figure 1: The basic diagrams in order to describe representations and morphisms of G . Refer to Section 2.3 for detailed explanations.

symmetry group is $G = SU(2)$, and the assignment of $6j$ -symbols to the tetrahedra can be obtained as a special case of the dual formulation of non-Abelian lattice gauge theory [7, 8, 12]. For each triangle we have a Haar intertwiner $T: V_j \otimes V_k \otimes V_\ell \rightarrow V_j \otimes V_k \otimes V_\ell$. The projectors $P^{(j)}$ in (2.13) are then $SU(2)$ intertwiners as in (1.1) and belong to two different $6j$ -symbols associated with the two tetrahedra attached to the triangle.

In order to perform calculations involving the Haar intertwiner, there exists a convenient diagrammatic language which can be understood as a specialization of the Reshetikhin–Turaev ribbon diagrams [13] to representations of compact Lie groups.

Figure 1 shows the basic diagrams. These are read from top to bottom. We draw directed lines which are labeled with finite-dimensional unitary representations ρ of G . If the arrow points down, the line denotes the identity map of V_ρ , Figure 1(a). If the arrow points up as in (b), it refers to the identity map of the dual representation V_ρ^* . Placing symbols next to each other corresponds to the tensor product, placing symbols below each other denotes the composition of maps. The diagrams (c) and (d) show co-evaluation and evaluation,

$$\text{coev}_\rho: \mathbb{C} \rightarrow V_\rho \otimes V_\rho^*, \quad 1 \mapsto \sum_{j=1}^{\dim V_\rho} v_j \otimes \eta^j, \quad (2.15)$$

$$\text{ev}_\rho: V_\rho^* \otimes V_\rho \rightarrow \mathbb{C}, \quad \alpha \otimes w \mapsto \alpha(w). \quad (2.16)$$

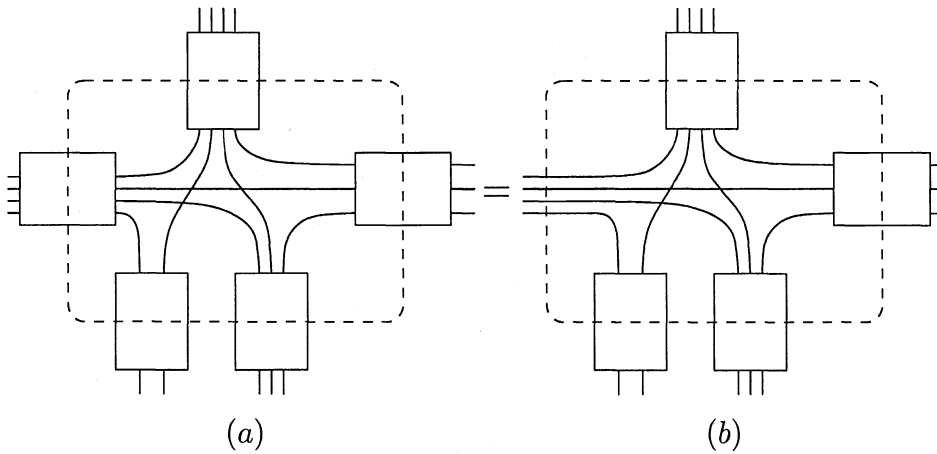

Figure 2: The gauge fixing relation, Proposition 2.7(5).

Two tensor factors are swapped by the map $\psi_{\rho,\sigma} : V_\rho \otimes V_\sigma \rightarrow V_\sigma \otimes V_\rho, v \otimes w \mapsto w \otimes v$ in diagram (e). The Haar intertwiner (2.11) is shown in (f). The trivial representation is invisible in these diagrams. Note that for representations of groups, as opposed to quantum groups or super groups, our diagrams do not involve any framing nor any non-trivial braiding. Any diagram that can be written down using only the symbols of Figure 1, is G -covariant, i.e. represents a G -morphism. The Haar intertwiner satisfies special properties [12] which are summarized by the following proposition.

Proposition 2.7. Let G be a compact Lie group and T denote the Haar intertwiner (2.10) for finite-dimensional unitary representations of G .

1. T is a G -morphism,
2. $T^2 = T$,
3. $T^\dagger = T$,
4. If Φ is a G -morphism, then $\Phi \circ T = T \circ \Phi$,
5. T satisfies the gauge fixing relation, i.e. in any diagram in which we can draw a closed loop (the dashed line in Figure 2(a)) which intersects only the boxes of Haar intertwiners, but no representation lines, then we may replace one of the Haar intertwiners by the identity morphism (Figure 2(b)). The step of going from (b) to (a) is called *inverse gauge fixing*.

Definition 2.8. Let ρ_1, \dots, ρ_k be finite-dimensional unitary representations of G . A diagram which represents a morphism $\Phi : V_{\rho_1} \otimes \dots \otimes V_{\rho_k} \rightarrow V_{\rho_1} \otimes$

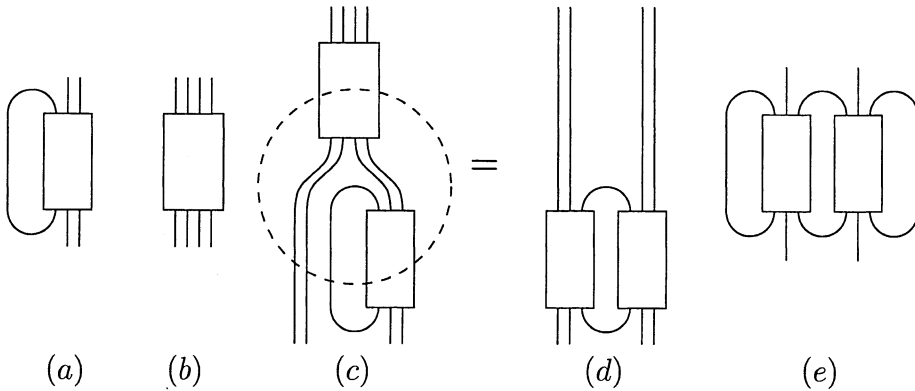

Figure 3: The anchor of the induction proof, see Lemma 3.1.

$\cdots \otimes V_{\rho_k}$, is called *positive* if Φ is a positive linear operator for any choice of finite-dimensional unitary representations for the ρ_1, \dots, ρ_k and for the internal lines of the diagram.

If we talk about positive diagrams, we can obviously omit the arrows from the diagrams because the above definition states a condition on all representations including in particular the dual ones. Our basic example of a positive diagram is the Haar intertwiner, Figure 1(f), or any partial trace of it.

3 Positivity of relativistic spin network evaluations

3.1 Positivity proof

In this section, we generate an infinite family of positive diagrams by induction. The anchor of the induction is the following lemma.

Lemma 3.1. The diagram in Figure 3(e) is positive.

Proof. We start with the diagrams in Figure 3(a) and (b). Diagram (a) is positive as a partial trace of the Haar intertwiner. Since it denotes a representation morphism, it commutes with the Haar intertwiner (b) by Proposition 2.7(4). Lemma 2.4(4) then implies the positivity of (c). From

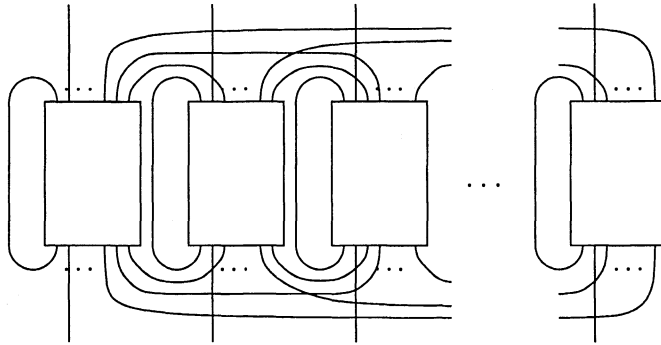

Figure 4: Theorem 3.2 establishes that this diagram is positive. It consists of k Haar intertwiners with $k + 1$ lines each. For each such Haar intertwiner, one line is an external one and one is a closed loop. Additionally, for each pair of Haar intertwiners, there is one loop linking the two.

there we obtain (d) by a sequence of inverse gauge fixing and gauge fixing along the dashed line in (c). Finally, (e) is positive as a partial trace of (d). \square

We wish to generalize this result to the diagram that generalizes Figure 3(e) to k Haar intertwiners and which is shown in Figure 4. This diagram consists of k Haar intertwiners with $k + 1$ lines each. For each such Haar intertwiner, one line is an external one and one is a closed loop. Additionally, for each pair of Haar intertwiners, there is one loop linking the two.

Theorem 3.2. The diagram of Figure 4 is positive for any number k of Haar intertwiners.

Proof. We assume that the theorem is true for $k - 1$ (for $k - 1 = 2$, this was proved in Lemma 3.1). In order to keep the drawings simple, Figure 5 shows the case $k = 3$. The argument is, of course, independent of k .

The diagram in Figure 5(a) is positive by assumption. Note that we are allowed to replace single lines by double lines in any positive diagram because positivity holds for any assignment of representations, in particular for tensor products. Diagram (a) denotes a morphism so that it commutes with the Haar intertwiner with four or more lines. Therefore diagram (b) is positive by Lemma 2.4(4). We obtain (c) by inverse gauge fixing and gauge

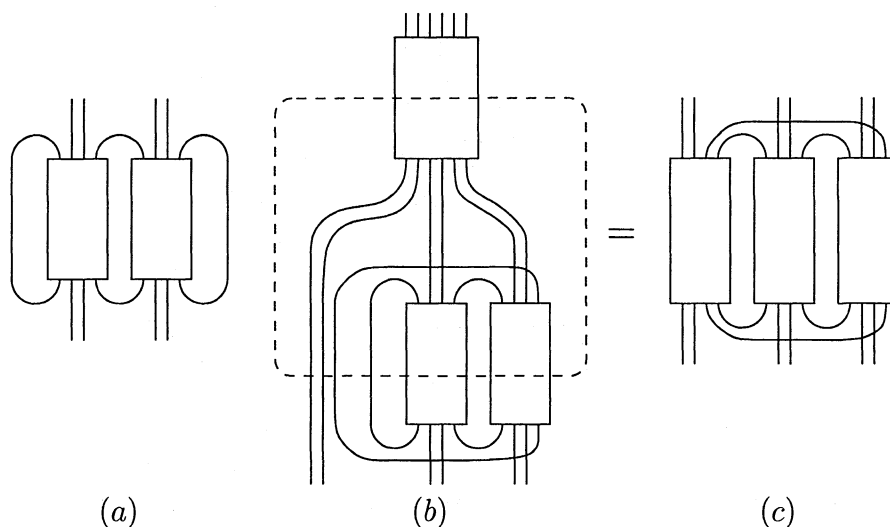

Figure 5: Diagrams used in the proof of Theorem 3.2.

fixing along the dashed line in (b). The proposition follows by exchanging tensor factors and taking partial traces. \square

3.2 Relativistic spin network evaluations

We have shown in Theorem 3.2 that the diagram of Figure 4 is positive. Now we choose the trivial representation for all external lines and for the little loops that are attached only to one Haar intertwiner, and obtain positive diagrams such as that in Figure 6(a) which was drawn for $k = 4$. If we view each pair of lines that belong to the same loop as a representation $V \otimes V^*$, these diagrams have the structure of the complete graph of k vertices, Figure 6(b). The spin network of Figure 6(a) is a relativistic spin network in the following sense.

Definition 3.3. Let G be a compact Lie group. A *relativistic spin network* with symmetry $G \times G$ is a spin network whose edges are labeled with representations of the form $V \otimes V^*$ of $G \times G$ where V denotes a representation of G , and whose vertices are labeled by the intertwiner of Figure 6(c), given by one integration over G .

Remark 3.4. 1. The relativistic spin networks used in the model of Barrett–Crane [4] form a special case of Definition 3.3 for $G = SU(2)$,

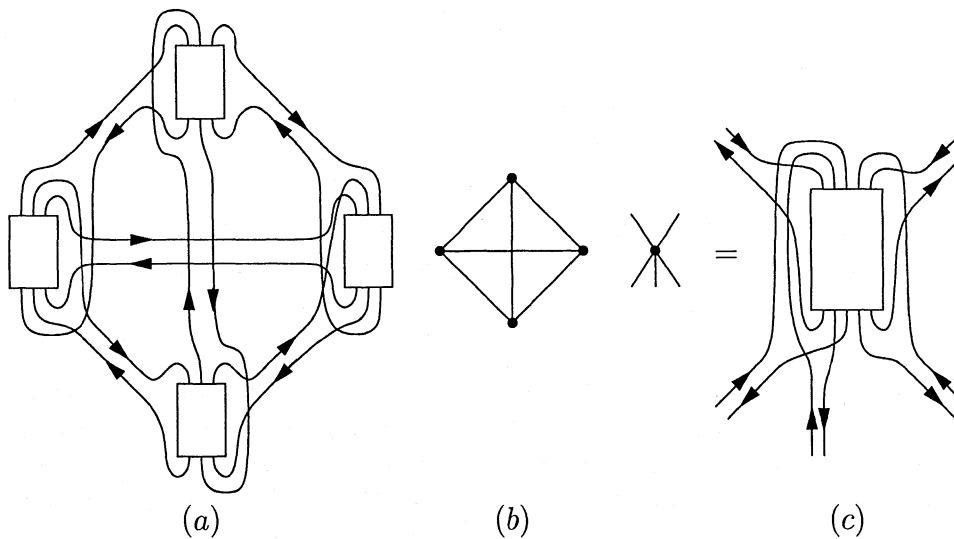

Figure 6: The structure of the positive diagrams (a) generated by Theorem 3.2 is that of a complete graph (b) where the representations are of the form $V \otimes V^*$ and the intertwiner is given by a group integration (c).

using $Spin(4) \cong SU(2) \times SU(2)$. For $SU(2)$, the balanced representations $V \otimes V$ are isomorphic to our representations $V \otimes V^*$, and Figure 6(c) is precisely the presentation [14] of the Barrett–Crane intertwiner as an integral over $SU(2) \cong S^3$.

2. Observe that the choice of $V \otimes V^*$ instead of the isomorphic $V \otimes V$ has eliminated a number of signs as we have already observed in [15]. There we have also shown that the choice $V \otimes V^*$ is the canonical one compatible with the integral presentation of the Barrett–Crane intertwiner.
3. Balanced representations of $Spin(4)$ factor through the covering map $Spin(4) \rightarrow SO(4)$ and therefore form representations of $SO(4)$.

Reisenberger [16] has proved that the space of Barrett–Crane intertwiners for any given valence of the vertex is one-dimensional. The particular prefactor can depend on the conventions used. For our definition using the integral presentation of the Barrett–Crane intertwiner and balanced representations of the form $V \otimes V^*$, the relativistic spin networks evaluate to non-negative numbers. If one uses, however, Kauffman’s conventions [17]

S_3	$[1^+]$	$[2]$	$[1^-]$
$()$	1	2	1
$(12), (13), (23)$	1	0	-1
$(123), (132)$	1	-1	1

Table 1: The character table of the finite group S_3 . The rows are labeled by its conjugacy classes and the columns by the finite-dimensional irreducible representations.

for $SU(2)$ spin networks, there is an additional overall sign which depends on the representations. This is the sign [6] that cancels only if one multiplies all spin networks associated to the four-simplices of a closed manifold. This sign is not essential to the spin network evaluation, but rather an artifact of conventions which are unnatural in the present context.

Theorem 3.2 has shown that relativistic spin networks on the complete graph of k vertices evaluate to non-negative numbers. This result can be specialized to any subgraph of the complete graph by choosing the trivial representation for all edges that are missing compared to the complete graph. We have therefore proved

Corollary 3.5. Let G be a compact Lie group. Any relativistic spin network with symmetry $G \times G$ on any subgraph of a complete graph evaluates to a non-negative real number.

The positivity of relativistic spin network evaluations proved so far implies that the individual summands of the partition function of the Barrett–Crane model on a generic two-complex are non-negative because these summands are products of various amplitudes each of which is calculated by evaluating relativistic spin networks. This result can be extended to prove the absence of destructive interference in the Riemannian Barrett–Crane model on any two-complex, using Corollary 1 of [6].

4 Counterexamples to the stronger conjecture

Given the result of Section 3, it is tempting to conjecture that the use of the Haar intertwiner is the magical ingredient that renders all these spin networks non-negative. However, the stronger conjecture that all diagrams are positive if they are composed only from the building blocks shown in Figure 1, is not true.

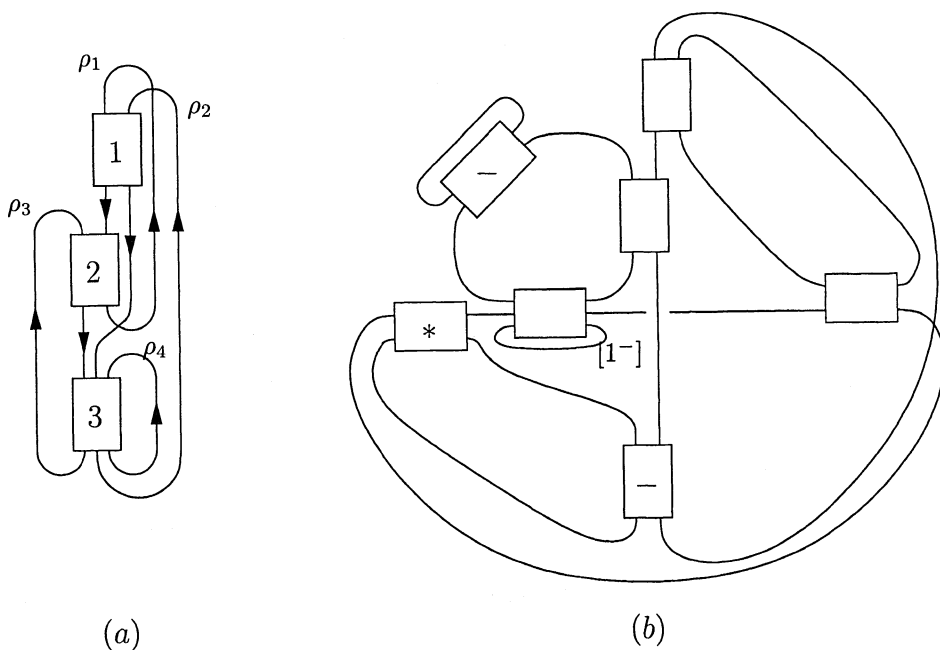

Figure 7: These diagrams are not positive.

As a first counterexample we consider the diagram in Figure 7(a). The compact Lie group G is the finite group S_3 (with the discrete topology). Its character table is given in Table 1. Let $[2]$ denote the two-dimensional representation of S_3 and $[1^-]$ the one-dimensional parity representation. If we choose $\rho_1 = \rho_2 = \rho_3 = [2]$ and $\rho_4 = [1^-]$, a direct calculation shows that Figure 7(a) evaluates to

$$\frac{1}{|S_3|^3} \sum_{f,g,h \in S_3} \chi^{[2]}(fg)\chi^{[2]}(fh)\chi^{[2]}(gh)\chi^{[1^-]}(h) = -\frac{1}{4}. \quad (4.1)$$

The stronger conjecture is therefore false, at least as long as we do not restrict the class of allowed Lie groups or the class of diagrams.

The diagrams studied in Section 3 are obviously special in the sense that they are related to relativistic spin networks. Is the counterexample presented above maybe too pathologic? It is instructive to re-arrange the positive diagrams of Section 3. For $k = 4$, we have Figure 6(a) which can be drawn as Figure 8. This is the diagram which appears in the study of lattice gauge theory on the two-complex dual to a triangulation of the sphere S^3 by

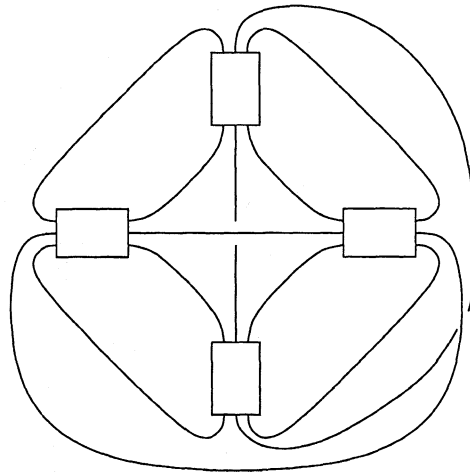

Figure 8: The diagram appearing in lattice gauge theory on the two-complex dual to a triangulation of the sphere S^3 by two tetrahedra.

two tetrahedra. One of the tetrahedra is located at the center of the diagram, the other one at infinity. In the language of [12], the diagram is the circuit diagram in the two-complex dual to the cellular decomposition defined by the triangulation. The diagram for general k is the circuit diagram for the triangulation of S^{k-1} by two $(k-1)$ -simplices.

Is it maybe true that the circuit diagrams of all triangulations or of all cellular decompositions of S^{k-1} have a positive evaluation? The answer is again negative as our second counterexample shows.

Consider the diagram in Figure 8. Subdivide the central tetrahedron into four tetrahedra ($1 \leftrightarrow 4$ Pachner move) and draw the circuit diagram for this finer triangulation. By gauge fixing and substituting the trivial representation for some lines, we arrive at the diagram of Figure 7(b). This diagram evaluates to a negative number for some choice of representations which implies that the diagram of the refined triangulation of S^3 is negative for some labeling.

In order to see this, consider Figure 7(b) and gauge fix again, removing the Haar intertwiner marked by a '*'. For any assignment of irreducible representations to the lines, a number of Haar intertwiners are trivial and can be explicitly evaluated. We remove two of them, marked by '-' from the

diagram. The resulting diagram can be computed by hand for $G = S_3$. We choose all representations to be $[2]$ except for the line indicated in Figure 7(b) which is labeled by $[1^-]$. The calculation is completely analogous to our first counterexample, and the diagram evaluates to $-1/8$.

We have therefore shown that the stronger conjecture fails even if one restricts the class of diagrams to circuit diagrams of triangulations of the sphere S^3 .

5 Discussion

First we point out a general difficulty with the definition of the Barrett–Crane model. Its vertex amplitude is found by geometrical conditions to be the ‘relativistic $10j$ -symbol’, defined by the requirement that its representations are balanced and that its intertwiners are Barrett–Crane intertwiners. This intertwiner is *a priori* only specified up to a complex factor. It would obviously be a disaster if, as a consequence, the full $10j$ -symbol contains an arbitrary complex factor. The standard strategy to avoid such an ambiguity is to fix the conventions for all intertwiners throughout the representation category of $SU(2)$ in a systematic way, for example, as in [17]. The remaining ambiguity is then still a representation dependent sign.

The construction presented here is, on the contrary, completely canonical. There are no arbitrary signs and we are in addition rewarded by a special property, namely the positivity of any single relativistic spin network. It should be pointed out that the Lorentzian versions of the relativistic spin networks were defined in terms of their integral presentation right in the beginning [18]. This definition is canonical, and there are no similar sign ambiguities there.

We observe that the framework developed in the present article extends to non-compact Lie groups G provided their representations are unitary and that one can show the existence of all relevant traces. The Lorentzian version of relativistic spin networks [18], however, has a different structure and is not covered by our result.

What are possible application of our positivity result? The Riemannian, *i.e.* $Spin(4)$ - or $SO(4)$ -symmetric, Barrett–Crane model can be defined on any two-complex, not just on a two-complex dual to a triangulation [3], leading to relativistic spin networks on general graphs as the vertex amplitudes rather than just $10j$ -symbols. Our result provides a canonical definition of these spin networks and establishes the positivity of each single diagram. As

a consequence, one can show the absence of destructive interference following [6]. This result supports the conjecture that the Barrett–Crane model does not define any unitary evolution operator, but rather some projector for which the spin network basis is very special and gives rise to only positive (or only negative) matrix elements.

In contrast to the Barrett–Crane model, lattice gauge theory and lattice sigma models are meant to be models of Statistical Mechanics with positive weights that admit a probability interpretation. For non-Abelian lattice gauge theory, our counterexample shows that the strong-weak dual spin foam model [7,8,12] does not in general have positive amplitudes. In order to apply Monte Carlo techniques, one therefore needs a special treatment of the signs. The situation for the spin network models strong-weak dual to lattice sigma models [11] is much better. Both the $G \times G$ -symmetric lattice chiral model and the $SO(4)$ -symmetric lattice non-linear sigma model, also called the 3-vector model, have dual descriptions in terms of relativistic spin networks so that we have non-negative amplitudes in these cases.

Acknowledgments

I would like to thank Robert Oeckl for stimulating discussions and for comments on the manuscript.

References

- [1] R. PENROSE: Angular momentum: an approach to combinatorial space-time. In *Quantum theory and beyond: essays and discussions arising from a colloquium*, ed. Ted Bastin. Cambridge University Press, Cambridge, 1971, pp. 151–180.
- [2] C. ROVELLI and L. SMOLIN: Spin networks and quantum gravity. *Phys. Rev. D* **52**, No. 10 (1995) 5743–5759, gr-qc/9505006.
- [3] J. C. BAEZ: Spin foam models. *Class. Quant. Grav.* **15**, No. 7 (1998) 1827–1858, gr-qc/9709052.
- [4] J. W. BARRETT and L. CRANE: Relativistic spin networks and quantum gravity. *J. Math. Phys.* **39**, No. 6 (1998) 3296–3302, gr-qc/9709028.

- [5] J. D. CHRISTENSEN and G. EGAN: An efficient algorithm for the Riemannian 10j symbols. *Class. Quant. Grav.* **19** (2002) 1185–1194, [gr-qc/0110045](#).
- [6] J. C. BAEZ and J. D. CHRISTENSEN: Positivity of spin foam amplitudes. *Class. Quant. Grav.* **19** (2002) 2291–2306, [gr-qc/0110044](#).
- [7] R. OECKL and H. PFEIFFER: The dual of pure non-Abelian lattice gauge theory as a spin foam model. *Nucl. Phys. B* **598**, No. 1-2 (2001) 400–426, [hep-th/0008095](#).
- [8] H. PFEIFFER: Four-dimensional Lattice Gauge Theory with ribbon categories and the Crane–Yetter state sum. *J. Math. Phys.* **42**, No. 11 (2001) 5272–5305, [hep-th/0106029](#).
- [9] M. REED and B. SIMON: *Functional Analysis. Methods of modern mathematical physics 1*. Academic Press, New York, 1972.
- [10] R. CARTER, G. SEGAL and I. MACDONALD: *Lectures on Lie groups and Lie algebras*. London Mathematical Society Student Texts 32. Cambridge University Press, Cambridge, 1995.
- [11] H. PFEIFFER: Exact duality transformations for sigma models and gauge theories (2002). Preprint [hep-lat/0205013](#).
- [12] R. OECKL: Generalized lattice gauge theory, spin foams and state sum invariants. To appear in *J. Geom. Phys.* (2002). Preprint [hep-th/0110259](#).
- [13] N. RESHETIKHIN and V. G. TURAEV: Ribbon graphs and their invariants derived from quantum groups. *Comm. Math. Phys.* **127** (1990) 1–26.
- [14] J. W. BARRETT: The classical evaluation of relativistic spin networks. *Adv. Th. Math. Phys.* **2**, No. 3 (1998) 593–600, [math/9803063](#).
- [15] H. PFEIFFER: Dual variables and a connection picture for the Euclidean Barrett–Crane model. *Class. Quant. Grav.* **19** (2002) 1109–1137, [gr-qc/0112002](#).
- [16] M. P. REISENBERGER: On relativistic spin network vertices. *J. Math. Phys.* **40**, No. 4 (1999) 2046–2054, [gr-qc/9809067](#).
- [17] L. H. KAUFFMAN and S. L. LINS: *Temperley-Lieb recoupling theory and invariants of 3-manifolds*. Princeton University Press, Princeton, 1994.

- [18] J. W. BARRETT and L. CRANE: A Lorentzian signature model for quantum general relativity. *Class. Quant. Grav.* **17**, No. 16 (2000) 3101–3118, [gr-qc/9904025](#).