

GENUS 1 FIBRATIONS ON THE SUPERSINGULAR K3 SURFACE IN CHARACTERISTIC 2 WITH ARTIN INVARIANT 1*

NOAM D. ELKIES[†] AND MATTHIAS SCHÜTT[‡]

Abstract. The supersingular K3 surface X in characteristic 2 with Artin invariant 1 admits several genus 1 fibrations (elliptic and quasi-elliptic). We use a bijection between fibrations and definite even lattices of rank 20 and discriminant 4 to classify the fibrations, and we exhibit isomorphisms between the resulting models of X . We also study a configuration of (-2) -curves on X related to the incidence graph of points and lines of $\mathbb{P}^2(\mathbb{F}_4)$.

Key words. K3 surface, supersingular, elliptic fibration, quasi-elliptic.

AMS subject classifications. 14J27, 14J28; 06B05, 11G25, 51A20, 14N20.

1. Introduction. Elliptic fibrations are a versatile tool for studying algebraic surfaces. One of their key advantages is that one can often compute the Néron-Severi lattice, and in particular the Picard number, in a systematic way. This has been carried out with great success in the study of K3 surfaces. There is one feature that singles out K3 surfaces among all algebraic surfaces admitting elliptic fibrations: a single K3 surface may admit several distinct elliptic fibrations.

Several previous papers classify all jacobian elliptic fibrations on a given class of K3 surfaces (i.e. elliptic fibrations with section). Oguiso determined all jacobian elliptic fibrations of a Kummer surface of two non-isogenous elliptic curves [14]. This classification was achieved by geometric means. Subsequently Nishiyama proved Oguiso's result again by a lattice theoretic technique [12]. Equations and elliptic parameters were derived by Kuwata and Shioda [10]. Nishiyama also considered other Kummer surfaces of product type and certain singular K3 surfaces. Kumar recently determined all elliptic fibrations on the Kummer surface of the Jacobian of a generic curve of genus 2 [9].

All these classifications are *a priori* only valid in characteristic zero. In this paper we present a classification that is specific to positive characteristic and does not miss any non-jacobian fibrations. Namely we consider the supersingular K3 surface X in characteristic 2 with Artin invariant 1. In this setting we must deal with quasi-elliptic fibrations whose general fiber is a cuspidal rational curve. As a uniform notation, we shall refer to either an elliptic or a quasi-elliptic fibration as a *genus 1 fibration*.

THEOREM 1. *Let X denote the supersingular K3 surface X with Artin invariant 1 over an algebraically closed field of characteristic 2. Then X admits exactly 18 genus 1 fibrations.*

A crucial ingredient of our main result is Theorem 2 stating that any genus 1 fibration on X admits a section. The classification of all possible fibrations is then achieved in Section 6 by lattice theoretic means *à la* Kneser-Nishiyama (cf. Section 5). We also determine whether the fibrations are elliptic or quasi-elliptic using a criterion

*Received December 19, 2012; accepted for publication March 20, 2014. Partial support from NSF under grant DMS-0501029 and ERC under StG 279723 (SURFARI) gratefully acknowledged.

[†]Mathematics Department, Harvard University, 1 Oxford Street, Cambridge, MA 02138, USA (elkies@math.harvard.edu).

[‡]Institut für Algebraische Geometrie, Leibniz Universität Hannover, Welfengarten 1, 30167 Hannover, Germany (schuett@math.uni-hannover.de).

developed in Section 4 (Theorem 7). The existence of these fibrations on X is established by exhibiting an explicit Weierstrass form over the prime field \mathbb{F}_2 for each of them. We shall furthermore connect all fibrations by explicit isomorphisms over \mathbb{F}_4 (usually even over \mathbb{F}_2 , but we shall see that this is not always possible). Equations and isomorphisms are given in Section 8. The uniqueness part of Theorem 1 is proven in Section 9 by working with explicit Weierstrass equations. Section 10 shows that some specific (-2) curves on X generate the incidence graph of points and lines in $\mathbb{P}^2(\mathbb{F}_4)$. We derive some surprising consequences for configurations in $\mathbb{P}^2(\mathbb{F}_4)$ such as the absence of a 14-cycle. The paper concludes with comments on the implications of our classification for reduction from characteristic zero.

2. The supersingular K3 surface in characteristic 2 with Artin invariant 1. On an algebraic surface S , we consider the Néron-Severi group $\text{NS}(S)$ consisting of divisors up to algebraic equivalence. The Néron-Severi group is finitely generated and abelian; its rank is called the Picard number of S and denoted by $\rho(S)$. The intersection form endows $\text{NS}(S)$ with the structure of an integral lattice up to torsion. By the Hodge index theorem, this lattice has signature $(1, \rho(S) - 1)$. On a K3 surface, algebraic and numerical equivalence are the same. Hence $\text{NS}(S)$ is torsion-free and thus a lattice in the strict sense.

In characteristic zero, Lefschetz' theorem bounds the Picard number by the central Hodge number:

$$(1) \quad \rho(S) \leq h^{1,1}(S).$$

In positive characteristic, however, we have only Igusa's theorem which gives the weaker upper bound:

$$(2) \quad \rho(S) \leq b_2(S).$$

Surfaces attaining equality in the former bound (1) are sometimes called singular (in the sense of exceptional, like elliptic curves are said to be "singular" when they have complex multiplication). Equality in the latter bound (2) leads to Shioda's notion of supersingular surfaces.

For K3 surfaces, one has $h^{1,1}(S) = 20$ and $b_2(S) = 22$. Supersingular K3 surfaces were studied by Artin in [1]. In particular he proved that for a supersingular K3 surface in characteristic p , the Néron-Severi group $\text{NS}(S)$ has discriminant

$$(3) \quad \text{disc}(\text{NS}(S)) = -p^{2\sigma}, \quad 1 \leq \sigma \leq 10.$$

Here σ is usually called the Artin invariant of S . Artin also derived a stratification of the moduli space of supersingular K3 surfaces in terms of σ . This classification was later complemented by Ogus who proved that there is a unique supersingular K3 surface with $\sigma = 1$ over the algebraic closure of the base field [16] (see [18] for characteristic 2).

From here on we specialize to characteristic $p = 2$. There are several known models for the unique supersingular K3 surface X with $\sigma = 1$ (e.g. [4], [6], [18], [22]). For instance one can take the following genus one fibration from [4] with affine parameter $t \in \mathbb{P}^1$:

$$X : y^2 = x^3 + t^3x^2 + t.$$

This fibration is quasi-elliptic, i.e. all fibers are singular curves (see Section 3), but it has only one reducible fiber. The special fiber is located outside the affine chart on

the base curve \mathbb{P}^1 , at $t = \infty$, and has Kodaira type I_{16}^* . It follows that there can be no sections other than the zero section O , and that

$$\text{NS}(X) = U \oplus D_{20}.$$

This fibration will reappear in our classification in Sections 6–8 as #18. Note that a singular fiber of type I_{16}^* is impossible for a jacobian genus 1 fibration on any K3 surface outside characteristic two, for otherwise the surface would contradict either (1) or (3). In comparison, for an elliptic K3 surface in characteristic two, the maximal singular fiber types are I_{13}^* and I_{18} by [21].

3. Genus one fibrations. A genus 1 fibration on a smooth projective surface S is a surjective morphism onto a smooth curve C such that the general fiber F is a curve of arithmetic genus 1. If the characteristic is different from 2 and 3, then this already implies that F smooth. In the presence of a section, F is an elliptic curve; hence these fibrations are called elliptic. In characteristics 2 and 3, however, F need not be smooth, it may be a cuspidal rational curve. Such a fibration is called quasi-elliptic.

For general properties of genus 1 fibrations (mostly elliptic), the reader is referred to the recent survey [25] and the references therein, specifically [3]. We shall review a few more details about quasi-elliptic fibrations in Section 9. Here we only recall two useful formulas. The first computes the Euler-Poincaré characteristic $e(S)$ through the (reducible) singular fibers. The sum includes a local correction term that accounts for the wild ramification δ_v in the case of an elliptic surface, and for the non-zero Euler-Poincaré characteristic of the general fiber in the case of a quasi-elliptic surface:

- S elliptic: $e(S) = \sum_{v \in C} (e(F_v) + \delta_v),$
- S quasi-elliptic: $e(S) = e(C)e(F) + \sum_{v \in C} (e(F_v) - 2).$

The Shioda-Tate formula concerns jacobian genus 1 fibrations. It asserts that the Néron-Severi group is generated by fiber components and sections. Outside the Mordell-Weil group, the only relation is that any two fibers are algebraically equivalent.

In order to find a genus 1 fibration on a K3 surface, it suffices to find a divisor D of zero self-intersection $D^2 = 0$ by [17]. Then either D or $-D$ is effective by Riemann-Roch, and the linear system $|D|$ or $|-D|$ induces a genus 1 fibration (usually elliptic). If the divisor D has the shape of a singular fiber from Kodaira’s list, then it in fact appears as a singular fiber of the given fibration. Moreover, any irreducible curve C with $C \cdot D = 1$ gives a section of the fibration.

In the K3 case, any curve has even self-intersection by the adjunction formula, so C^2 is even. Hence C and D span the hyperbolic plane U . In summary, a jacobian elliptic fibration on a K3 surface is realized by identifying a copy of U inside NS . (Warning: in general it might not be the copy of U we started with, because the sections of D may have a base locus. But it is always the image of the original copy of U under an isometry of $\text{NS}(S)$.) We now prove a result which implies that any genus one fibration on X is jacobian:

THEOREM 2. *Any genus 1 fibration on a supersingular K3 surface of Artin invariant 1 admits a section.*

Proof. Let X denote the supersingular K3 surface of Artin invariant 1 in characteristic p . Given a genus 1 fibration, we denote the class of a fiber by F and the multisection index by $m \in \mathbb{N}$. That is,

$$m\mathbb{Z} = \{D.F, D \in \text{NS}(X)\}.$$

Then the fibration has a section if and only if $m = 1$. Assume $m > 1$. Then $F/m \in \text{NS}(X)^\vee$, and in fact

$$N := \langle \text{NS}(X), F/m \rangle \text{ is an even integral lattice,}$$

since $F^2 = 0$. Presently F is indivisible in $\text{NS}(X)$ since there cannot be any multiple fibers by the canonical bundle formula (see [25, Thm. 6.8]). Hence $\text{NS}(X)$ has index m in N from which we infer

$$\text{disc}(N) = \text{disc}(\text{NS}(X))/m^2.$$

Since the discriminant is an integer, it follows at once that $m = p$. But even then, N is a unimodular lattice of signature $(1, 21)$ which gives a contradiction. \square

REMARK 3. The above argument may be applied to any elliptic surface with indivisible fiber class. In fact, one may compare Keum's result for complex elliptic K3 surfaces [7] which states in the analogous notation that $\text{NS}(\text{Jac}(X)) = N$.

Throughout this paper we shall employ the following terminology. Kodaira's notation for singular fibers of type I_n (and III, IV) will be used interchangeably with the corresponding extended Dynkin diagrams \tilde{A}_{n-1} or the root lattices A_{n-1} , and likewise for $\tilde{D}_n, D_n (n \geq 4)$ and $\tilde{E}_n, E_n (n = 6, 7, 8)$. In principle, there is an ambiguity for A_1 and A_2 , but throughout this paper the root lattice will in fact determine the fiber type uniquely. The zero section will be denoted by O . The fiber component meeting O is called the identity component. For other simple components, we use the self-explanatory terms far component ($\tilde{D}_n (n > 4), \tilde{E}_6, \tilde{E}_7$), near component ($\tilde{D}_n (n > 4)$) and opposite component as well as even and odd components (\tilde{A}_n, n odd).

4. Elliptic vs. quasi-elliptic fibrations. We have already mentioned the subtlety in characteristics $p = 2$ and 3 that there are quasi-elliptic fibrations. This brings us to the question how to detect from $\text{NS} = U + M$ whether the corresponding genus 1 fibration is elliptic or quasi-elliptic. In this section, we shall discuss a few criteria.

A first criterion comes from the singular fibers: namely a quasi-elliptic fibration does not admit multiplicative fibers. The additive fiber types are also restricted:

- no $IV, IV^*, I_n^* (n > 0 \text{ odd})$ in characteristic 2,
- no III, III^* or $I_n^* (n \geq 0)$ in characteristic 3.

The Euler-Poincaré characteristic gives a second simple approach to distinguish elliptic and quasi-elliptic fibrations: on a quasi-elliptic fibration, only the reducible singular fibers contribute to $e(X)$ (which can also be computed as alternating sum of Betti numbers or with Noether's formula). If the sum over the fibers indeed returns the right number, then we can compare to the sum without the correction terms for the general fiber (plus possibly wild ramification which necessarily is non-zero for certain fiber types by [24]). If the latter sum exceeds $e(X)$, then the fibration cannot be elliptic. This criterion can be very useful because the reducible singular fibers are visible in $\text{NS}(X)$ by the Shioda-Tate formula.

The perhaps most general approach relies on the fact that quasi-elliptic surfaces are always unirational, hence supersingular. On the other hand, the MW-group of a quasi-elliptic fibration is always finite and in fact p -elementary (i.e. isomorphic to $(\mathbb{Z}/p\mathbb{Z})^r$ for some $r \in \mathbb{N}$). This leads to the following criterion:

THEOREM 4 (Rudakov-Shafarevich [19, §4]). *Given a genus 1 fibration on some algebraic surface X with $\chi(\mathcal{O}_X) > 1$ in characteristic p , not necessarily jacobian. This fibration is quasi-elliptic if and only if the following conditions are satisfied:*

- (i) $p = 2$ or 3 ,
- (ii) the root lattice of each reducible fiber has p -elementary discriminant group,
- (iii) the fiber components generate a sublattice of $\text{NS}(X)$ of corank one.

Specifically this implies for a jacobian quasi-elliptic fibration that the Mordell-Weil group is p -elementary because the fibers do not accommodate any higher torsion. We shall now discuss whether this last property already determines if the fibration is quasi-elliptic.

If the quasi-elliptic fibration from Theorem 4 is jacobian, then condition (iii) requires that the fibration is extremal. In general this means that the Picard number is maximal (relative to the inequality (1) or (2) depending on the characteristic) while the Mordell-Weil group is finite.

Extremal elliptic surfaces are much more special in positive characteristic than in characteristic zero. In fact, Ito showed that in characteristic p extremal elliptic surfaces always arise through purely inseparable base change from rational elliptic surfaces [5]. (Thus they are again unirational.) Going through all extremal rational elliptic surfaces and their purely inseparable base changes, one can thus deduce the following solution to the above problem:

PROPOSITION 5. *Let X be a jacobian genus 1 fibration of a supersingular surface in characteristic 2. If the Mordell-Weil group of the fibration is 2-elementary then X is either a rational elliptic surface or quasi-elliptic.*

REMARK 6. In characteristic 3, an analogous classification holds true with one series of surfaces added: elliptic surfaces with exactly two singular fibers, one of them of type I_{3e} for some $e \in \mathbb{N}$ and the other of type II if e is even, or IV^* if e is odd (with wild ramification of index one). These surfaces arise from the rational elliptic surface $y^2 + xy + tx = x^3$ through the purely inseparable base change $t \mapsto t^{3^e}$. Note that these elliptic fibrations are easy to distinguish from quasi-elliptic fibrations thanks to the multiplicative fiber at $t = 0$.

THEOREM 7. *Let X be a K3 surface over an algebraically closed field of characteristic p . Then a given jacobian genus 1 fibration on X is quasi-elliptic iff $p = 2, 3$, X is supersingular and $MW = (\mathbb{Z}/p\mathbb{Z})^r$ for some $r \in \mathbb{N}$.*

Proof. Quasi-elliptic fibrations only occur in the specified characteristics. For $p = 2$, the theorem follows from Proposition 5. For $p = 3$, we also have to take into account the extra case from Remark 6. But this series of surfaces avoids K3 surfaces by inspection of the Euler-Poincaré characteristic, so the claim follows. \square

The theorem (as well as the preceding proposition) is useful from the lattice theoretic viewpoint for the following reason: As we have seen in the previous section, a jacobian genus 1 fibration on an algebraic surface X corresponds to a decomposition of the Néron-Severi lattice $\text{NS}(X) = U + M$. Here M is often called the essential lattice. If $\chi(\mathcal{O}_X) > 1$, then M together with its root type determines the structure of the singular fibers and the Mordell-Weil group [28]. Since a K3 surface has $\chi = 2$, we can thus deduce from the essential lattice M whether a given jacobian genus 1 fibration on a K3 surface in characteristic 2 or 3 is elliptic or quasi-elliptic.

5. Kneser-Nishiyama method. In [12], Nishiyama introduced a lattice theoretic approach to classify all jacobian elliptic fibrations on a complex (elliptic) K3 surface. The method is based on gluing techniques of Kneser and Witt [8] and the

classification of Niemeier lattices, i.e. negative-definite unimodular lattices of rank 24. By [11], there are 24 such lattices, and each is determined by its root type. In fact, except for the Leech lattice, the root type has always finite index in the unimodular lattice.

For a complex K3 surface X , one has $\text{NS}(X)$ of rank $\rho(X) \leq 20$. The transcendental lattice $T(X)$ is defined as the orthogonal complement of $\text{NS}(X)$ in $H^2(X, \mathbb{Z})$ with respect to cup-product:

$$T(X) = \text{NS}(X)^\perp \subset H^2(X, \mathbb{Z}).$$

Since $H^2(X, \mathbb{Z})$ has signature $(3, 19)$, the signature of $T(X)$ is $(2, 20 - \rho(X))$. The information how to glue together $\text{NS}(X)$ and $T(X)$ in the unimodular lattice $H^2(X, \mathbb{Z})$ is encoded in the isomorphism of the discriminant forms:

$$q_{\text{NS}(X)} \cong -q_{T(X)}.$$

One now looks for a partner lattice L of $T(X)$ with rank $26 - \rho(X)$ such that L is negative definite of discriminant form $q_L = q_{T(X)}$. Such a lattice exists by lattice theory *à la* Nikulin (cf. [13]). Then one determines all primitive embeddings of L into Niemeier lattices N . For each embedding $L \hookrightarrow N$, the orthogonal complement $M = L^\perp \subset N$ is a candidate for the essential lattice of a jacobian elliptic fibration on X .

To show that X does indeed admit an elliptic fibration with essential lattice M , one notes that by construction the lattices $\text{NS}(X)$ and $U + M$ have the same signature and discriminant form. Thanks to the copy of the hyperbolic plane, these conditions imply that the lattices are isomorphic. But then the representation of $\text{NS}(X)$ as $U + M$ induces a jacobian elliptic fibration on X with essential lattice M , as we explained in Section 3.

Note that the same approach is not guaranteed to work in characteristic $p > 0$. Indeed, consider supersingular K3 surfaces of Artin invariant $\sigma > 2$. Here $\text{NS}(X)$ is p -elementary; hence its discriminant group has length 2σ . Assume that $\text{NS}(X) = U + M$, and that M is embedded primitively into some unimodular lattice N . Then the discriminant group G_L of its orthogonal complement L has the same length 2σ . In particular we can estimate the rank of N by

$$\text{rank}(N) = \text{rank}(M) + \text{rank}(L) \geq \text{rank}(M) + \text{length}(G_L) = 20 + 2\sigma > 24.$$

However, we can still try to pursue the same approach for supersingular K3 surfaces with Artin invariant $\sigma \leq 2$. This only requires finding a suitable partner lattice L for $\text{NS}(X)$. In the present situation, we have already mentioned that one way to write $\text{NS}(X)$ is $\text{NS}(X) = U \oplus D_{20}$. Hence we can choose $L = D_4$. In fact, the Niemeier lattice with root system D_{24} contains D_4 and D_{20} as primitive orthogonal sublattices. With the partner lattice D_4 , we can now classify all genus 1 fibrations on X (automatically jacobian by Theorem 2) and decide whether they are elliptic or quasi-elliptic by Theorem 7.

Note that by Theorem 7 it will be immediately clear from the embedding of D_4 into the Niemeier lattice whether the resulting genus 1 fibration has non-torsion sections (and thus is elliptic). Namely D_4 embeds into all root lattices of type D_n ($n \geq 4$), E_n ($n = 6, 7, 8$), but not into any A_n . The orthogonal complement of this embedding is always a root lattice (and therefore corresponds to fiber components) unless the overlattice in question is D_5 or E_6 . In the latter cases, the Mordell-Weil rank thus has to be positive, equaling one resp. two.

6. Genus one fibrations on X . This section gives the primitive embeddings of $L = D_4$ into Niemeier lattices. By the previous section, this describes all genus 1 fibrations on our K3 surface X . The following table lists the root type $R(N)$ that characterizes the corresponding Niemeier lattice N uniquely. The next entry is the root type $R(M)$ of the orthogonal complement of the primitive embedding of $L = D_4$ into N . Since this will serve as essential lattice M of an elliptic fibration, it encodes the reducible singular fibers. The difference of the ranks of $R(M)$ and M (the latter being 20) gives the MW-rank. As explained above, the MW-rank is positive if and only if D_4 is embedded into D_5 or E_6 . By [28] we obtain the torsion subgroup of MW from the primitive closure $R(M)'$ of $R(M)$ inside NS:

$$\text{MW}(X)_{\text{tor}} \cong R(M)' / R(M).$$

Then Proposition 5 tells us whether the fibration will be elliptic or quasi-elliptic, as indicated in the last column.

#	$R(N)$	$R(M)$	rk(MW)	Torsion	elliptic?
1	$D_4A_5^4$	A_5^4	0	3×6	e
2	D_4^6	D_4^5	0	2^4	qe
3	$D_5^2A_7^2$	$D_5A_7^2$	1	8	e
4	$D_6A_9^2$	$A_1^2A_9^2$	0	10	e
5	D_6^4	$A_1^2D_6^3$	0	2^3	qe
6	$E_6D_7A_{11}$	D_7A_{11}	2	4	e
7	$E_6D_7A_{11}$	$A_3E_6A_{11}$	0	6	e
8	E_6^4	E_6^3	2	3	e
9	D_8^3	$D_4D_8^2$	0	2×2	qe
10	D_9A_{15}	D_5A_{15}	0	4	e
11	E_7A_{17}	$A_1^3A_{17}$	0	6	e
12	$E_7^2D_{10}$	$A_1^3E_7D_{10}$	0	2×2	qe
13	$E_7^2D_{10}$	$D_6E_7^2$	0	2	qe
14	D_{12}^2	D_8D_{12}	0	2	qe
15	E_8D_{16}	D_4D_{16}	0	2	qe
16	E_8D_{16}	$D_{12}E_8$	0	1	qe
17	E_8^3	$D_4E_8^2$	0	1	qe
18	D_{24}	D_{20}	0	1	qe

TABLE 6.1
Genus one fibrations on X

A priori there is one ambiguity in the table: the root lattice of type A_1 can correspond to singular fibers of type I_2 or III . In the present situation, this problem is solved as follows:

If the fibration is quasi-elliptic, then all singular fibers are additive. Hence the above fibers have type III .

If the fibration is elliptic, then in each case involving an A_1 there is torsion in MW of order relatively prime to 2. Since fibers of type III do not accommodate ℓ -torsion sections outside characteristic ℓ ($\ell \neq 2$), the fibers corresponding to A_1 's have type I_2 .

Table 6.1 settles the classification statement of Theorem 1. It remains to prove

existence and uniqueness for each genus 1 fibration. This will be achieved in Section 8, as outlined in the next section, and Section 9.

REMARK 8. In our concrete situation, we can also distinguish elliptic and quasi-elliptic fibrations, given a decomposition $NS(X) = U + M$, by computing the Euler-Poincaré characteristics of the singular fibers instead of appealing to Theorem 7. Since some additive fiber types on an elliptic fibration necessarily come with wild ramification by [24], this in fact suffices for all cases but #18 which is implied by [21] to be quasi-elliptic.

Several of the fibrations from Table 6.1 have been studied by Dolgachev and Kondō in [4], by Ito in [5], and by one of us in [22], see also [6], [15, App. 2], [18], [20], [27, Ex. 4.1] as indicated in the following sections. Here we complement the previous considerations to derive equations and connections for all fibrations. We conclude this section with a remark about Picard numbers over finite fields. For each fibration, we will exhibit a model over \mathbb{F}_2 with Picard number 22 over \mathbb{F}_4 . However, the question of the Picard number over \mathbb{F}_2 is more subtle. We will see in the next section that the first two fibrations admit models X with $\rho(X/\mathbb{F}_2) = 15$. This cannot be improved because of the Galois action on the singular fibers and their components (or on the Mordell-Weil group). In contrast, for all other fibrations we will exhibit models with $\rho(X/\mathbb{F}_2) = 21$. This is optimal for supersingular K3 surfaces by [1, (6.8)] (see also [22, Thm. 4.4], [23]). More precisely, we will show that all models with $\rho(X/\mathbb{F}_2)$ fixed (i.e. 15 or 21) are isomorphic over \mathbb{F}_2 . In order to move between these two groups, we will exhibit two different models of #5 which are isomorphic over $\mathbb{F}_4 = \mathbb{F}_2(\varrho)$ with $\varrho^2 + \varrho + 1 = 0$.

7. Plan for connections. Let S be a projective K3 surface. Recall that it suffices to identify a divisor D on S that has the shape of a singular fiber from Kodaira’s list in order to find an genus 1 fibration on S with D as singular fiber. The fibration is induced by the linear system $|D|$. Moreover, any irreducible curve C with $C \cdot D = 1$ gives a section of the fibration.

With these tools at hand, it is in principle possible to derive all fibrations in Table 6.1 from a single model of the surface X . In practice, however, it is often easier to pursue this aim in several steps, since one can usually find only a few linear systems without too much effort. The following diagram sketches how we will connect all fibrations. The numbers refer to the figures in the next section where the connections are derived (or in one case to a subsection which provides a further reference).

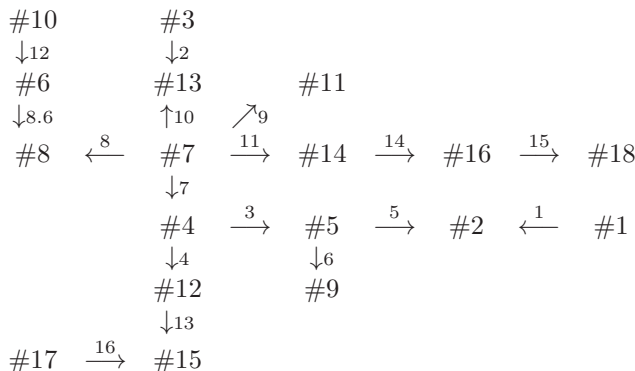

8. Equations & Connections. Usually we shall use affine coordinates x, y, t with t as the parameter of the base curve \mathbb{P}^1 over \mathbb{F}_2 . The new parameter will be denoted by u , i.e. it exhibits a new genus 1 fibration on X by the surjection

$$X \rightarrow \mathbb{P}^1$$

$$(x, y, t) \mapsto u(x, y, t)$$

A 5-tuple $[a_1, a_2, a_3, a_4, a_6]$ refers to the usual shorthand notation for the elliptic curve

$$y^2 + a_1xy + a_3y = x^3 + a_2x^2 + a_4x + a_6.$$

This fibration is quasi-elliptic in characteristic 2 if and only if $a_1 \equiv a_3 \equiv 0$ identically.

8.1. #1: $R(M) = A_5^4$. This fibration arises as inseparable base change from the Hesse pencil (see [27, Ex. 4.1]):

$$(4) \quad X : x^3 + y^3 + z^3 = t^2xyz.$$

A Weierstrass model can be found for instance in [5]. We have sections at the base points of the cubics (induced from the Hesse pencil) plus the likes of $[x, y, z] = [t, 1, 1]$. In total the sections are always given by $x^3 = z^3$ or $y^3 = z^3$ or $x^3 = y^3$.

Connection with #2. We can extract \tilde{D}_4 divisors from sections and fiber components.

We shall work affinely in the chart $z = 1$. For instance by setting $u = y$, we visibly arrange for \tilde{D}_4 fibers at $u = 0, \infty$.

In the sequel we will draw figures with fiber components and sections to visualize the connections. We will distinguish as follows between old and new fibration:

old fiber components	balls
old sections	small circles
new fibers	framed by boxes
new sections	big circles

The center of the following figure sketches the components of the I_6 fiber at $t = \infty$. We identify the fiber components C_x, C_y, C_z given by $x = 0$ resp. $y = 0$ resp. $z = 0$ of the model (4). The other three components arise as the exceptional divisors above the singular points at their intersections. The given sections come from the base points of the Hesse pencil with $y = 0, x^3 = z^3$ (LHS) or $x^3 = y^3, z = 0$ (RHS). The component C_x serves as a section of the new fibration.

This yields the quasi-elliptic fibration

$$X : t^2 = ux(x^3 + u^3 + 1).$$

This can be transformed into Weierstrass form as follows. First homogenize the RHS as a quartic polynomial with variable z . Setting $x = 1$, we obtain a cubic in Weierstrass form up to some factors:

$$X : t^2 = u((u^3 + 1)z^3 + 1).$$

The change of variables $(z, t) \mapsto (z/(u(u^3 + 1))^2, t/(u(u^3 + 1))^2)$ then returns the Weierstrass form

$$X : t^2 = z^3 + u^3(u^3 + 1)^2.$$

One reads off singular fibers of type \tilde{D}_4 at $u = 0, \infty$ (as seen above) and at the roots of $u^3 + 1$.

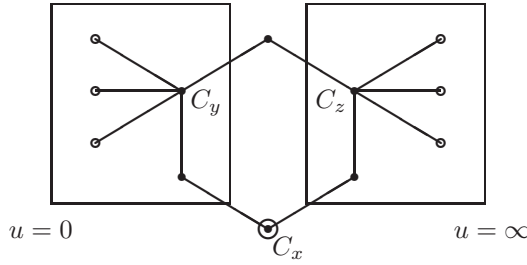

FIG. 1. Two \tilde{D}_4 divisors supported on \tilde{A}_5 and sections

8.2. #2: $R(M) = D_4^5$. This fibration admits several nice models, for instance $[0, 0, 0, 0, (t^3 + 1)^3]$ with singular fibers at all points of $\mathbb{P}^1(\mathbb{F}_4)$ as seen above. There are plenty of automorphisms respecting the fibration, for instance

$$\alpha : (x, y, t) \mapsto (\varrho x, y, t)$$

for $\varrho^3 = 1$ and those induced by Möbius transformations of \mathbb{P}^1 that permute ∞ and third roots of unity such as

$$(x, y, t) \mapsto (x/(t + 1)^4, y/(t + 1)^6, t/(t + 1)).$$

MW = $(\mathbb{Z}/2\mathbb{Z})^4$ with sections $P = (t^3 + 1, 0), Q = (t(t^3 + 1), (t^3 + 1)^2)$ plus images under the above automorphisms.

As an example, we give two connections, but we shall not use them here, since they do not lead to models with maximal Picard number $\rho(X/\mathbb{F}_2) = 21$ although the new fibrations admit such models (cf. 8.5). In the sequel, we shall only give the connections needed for the proof of Theorem 1.

Connection with #3. $u = y/((t^2 + t + 1)(x + t^3 + 1))$ extracts (independently at $u = 0$ and ∞) two \tilde{A}_7 divisors from pairs of two \tilde{D}_4 fibers connected through two sections.

Connection with #8. $u = y/(t^3 + 1)^2$ extracts \tilde{E}_6 from \tilde{D}_4 at ∞ and two-torsion sections $P, \alpha P, \alpha^2 P$ at $u = 0$. Same at $u = \infty$ from zero-section plus identity and double components of \tilde{D}_4 fibers at roots of $t^3 + 1$. The remaining simple components of the fibers at the roots of $t^3 + 1$ serve as sections.

8.3. #3: $R(M) = D_5 A_7^2$. From #2, we can obtain the model of #3 as cubic pencil

$$X : (x^2 + x + 1)(y + 1) = u^2(y^2 + y + 1)(x + 1).$$

This fibration is a purely inseparable base change by $s = u^2$ from a rational elliptic surface S with singular fibers of types twice I_4 and once III . Here the III -fiber comes with wild ramification of index one; since the ramification index stays constant under the base change, the special fiber is replaced by type I_1^* as claimed. The base points of the pencil generate $MW(S) \cong \mathbb{Z} \times \mathbb{Z}/4\mathbb{Z}$.

We find generators of $MW(X)$ in terms of another model of this elliptic fibration which also has the advantage of maximal Picard number $\rho(X/\mathbb{F}_2) = 21$. It arises from

the extremal rational elliptic surface $[1, s^2, s^2, 0, 0]$ with singular fibers of type I_8 at $t = 0$ and III at ∞ through the base change $t \mapsto s = t^2 + t$:

$$(5) \quad X : y^2 + xy + (t^2 + t)^2 y = x^3 + (t^2 + t)^2 x^2.$$

Next to the induced torsion sections $(s^2, 0), (0, 0), (0, s^2)$, there is an 8-torsion section $P = (t^2(t + 1), t^4(t + 1))$. Moreover there is an induced section $Q = (t^2, \rho t^4)$ of height 1. By computing the discriminant of $NS(X)$, one verifies that these sections generate $MW(X)$.

Connection with #13. $u = (x + s^2)/s^4$ extracts an \tilde{E}_7 at $u = \infty$ from the \tilde{A}_7 at $s = 0$ and the zero section. The non-identity components of the other \tilde{A}_7 together with the two-torsion section $Q = (0, 0)$ form another \tilde{E}_7 at $u = 1$. This leaves a root lattice D_5 (\tilde{D}_5 minus identity component) at ∞ disjoint from the two \tilde{E}_7 's. On the new fibration it results in a singular fiber of type \tilde{D}_6 at $u = 0$. As a new section, one can take P .

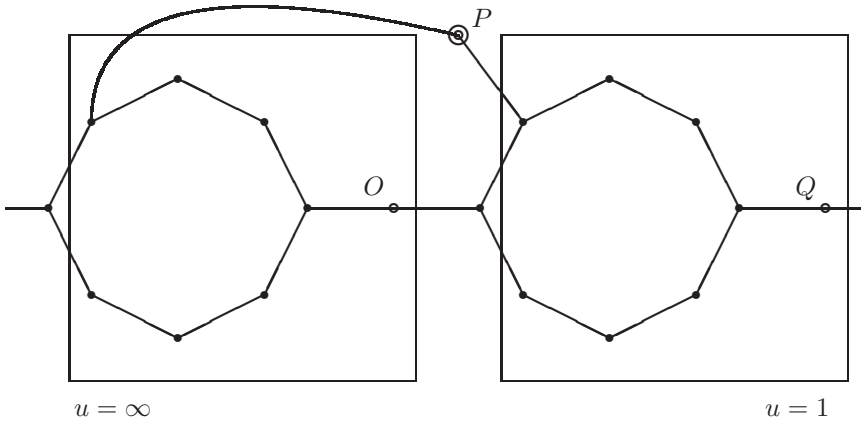

FIG. 2. Two \tilde{E}_7 divisors supported on two \tilde{A}_7 's and sections

We take this example as an opportunity to explain how one can derive the Weierstrass form of the new fibration explicitly. In general, it is often instructive to work with some resolution of singularities related to the new coordinate u . Here it concerns the A_7 singularity of the Weierstrass form (5) at $(x, y, s) = (0, 0, 0)$. We proceed in two steps, always choosing an appropriate affine chart. Blowing up twice yields affine coordinates

$$x = s^2 x'', y = s^2 y''.$$

The Weierstrass form transforms as

$$(6) \quad X : y''^2 + x'' y'' + (s + 1)^2 y'' = s^2 x''^3 + (s^2 + s)^2 x''^2.$$

Here the section P takes the shape $(x'', y'') = (s + 1, s^2(s + 1))$. The node of the above fibration in the fiber $s = 0$ sits at $(x'', y'') = (1, 0)$. Hence we translate x'' by 1 and then blow up two more times. This brings us exactly to the coordinate u from above (and another coordinate v):

$$x'' = s^2 u + 1, y'' = s^2 v.$$

Here (6) transforms as

$$(7) \quad X : v^2 + uv + v = s^4u^3 + s^4u^2 + u + 1.$$

The section P is expressed as $(u, v) = (1/s, s + 1)$. Now we want to consider (7) as an elliptic fibration onto $u \in \mathbb{P}^1$. Then P gives us the section $(s, v) = (1/u, 1 + 1/u)$. In order to obtain a Weierstrass form, we first translate s and v by the coordinates of the section. This gives

$$X : v^2 + (u + 1)v = u^2(u + 1)s^4.$$

We now modify $v \mapsto sv$, yielding the following plane cubic

$$X : sv^2 + (u + 1)v = u^2(u + 1)s^3.$$

Next we homogenize by the variable w and set $v = 1$ to obtain the following quasi-elliptic fibration:

$$X : (u + 1)w^2 = u^2(u + 1)s^3 + s.$$

Finally the variable change $(s, w) \mapsto (s/(u(u + 1))^2, w/(u^2(u + 1)^3))$ gives the Weierstrass form

$$X : w^2 = s^3 + u^2(u + 1)^3s.$$

One immediately checks that this has singular fibers of type \tilde{D}_6 at $u = 0$ and \tilde{E}_7 at $u = 1, \infty$ as predicted. Similar computations apply to all other connections.

8.4. #4: $R(M) = A_1^2A_9^2$. This fibration arises from (the mod 2 reduction of) the universal elliptic curve for $\Gamma_1(5)$ by purely inseparable base change. A model can be given as $[t^2 + 1, t^2, t^2, 0, 0]$ with \tilde{A}_9 's at $0, \infty$ and \tilde{A}_1 's at the roots of $t^2 + t + 1$. MW = $\mathbb{Z}/10\mathbb{Z}$ with 5-torsion section induced from the universal elliptic curve, generated by $(0, 0)$ or $(t^2, 0)$ for instance. As an extra feature there is a 2-torsion section $(t^2/(t + 1)^2, t^4/(t + 1)^3)$ meeting the zero section. (This can only happen for p^n -torsion in characteristic p ; Shioda calls such torsion sections peculiar in [15]). Sections of order ten are e.g. $P = (t, t)$ and $(t^2 + t^3, t^4)$.

Connection with #5. $u = x/t^2$ extracts \tilde{D}_6 from \tilde{A}_9 's and zero section. The remaining fiber components combine with sections $4P, 6P$ (at $t = 0$) resp. $2P, 8P$ (at $t = \infty$) for two further copies of \tilde{D}_6 . A_1 's stay unchanged.

The eight 2-torsion sections of the new fibration come from the remaining four fiber components of the two \tilde{A}_9 fibers and the four 10-torsion sections $P, 3P, 7P, 9P$.

Connection with #12. $u = x$ extracts \tilde{E}_7 from \tilde{A}_9 at ∞ and zero section. Non-identity components of \tilde{A}_9 at $t = 0$ and sections $2P, 8P$ form \tilde{D}_{10} ; the two A_1 's formed by the non-identity fiber components at roots of $t^2 + t + 1$ remain, and there is another A_1 given by the opposite component of the \tilde{A}_9 at ∞ . The sections of #12 are thus given by the two fiber components indicated in the figure, and by the old sections $P, 9P$.

8.5. #5: $R(M) = A_1^2D_6^3$. For this quasi-elliptic fibration, we shall exhibit two models in order to transfer from the models with $\rho(X/\mathbb{F}_2) = 15$ (#'s 1, 2) to all other fibrations with optimal models of $\rho(X/\mathbb{F}_2) = 21$. We start with the quasi-elliptic fibration $[0, 0, 0, t(t^3 + 1)^2, 0]$ with \tilde{D}_6 's at roots of $t^3 + 1$ and \tilde{A}_1 's at $t = 0, \infty$. This

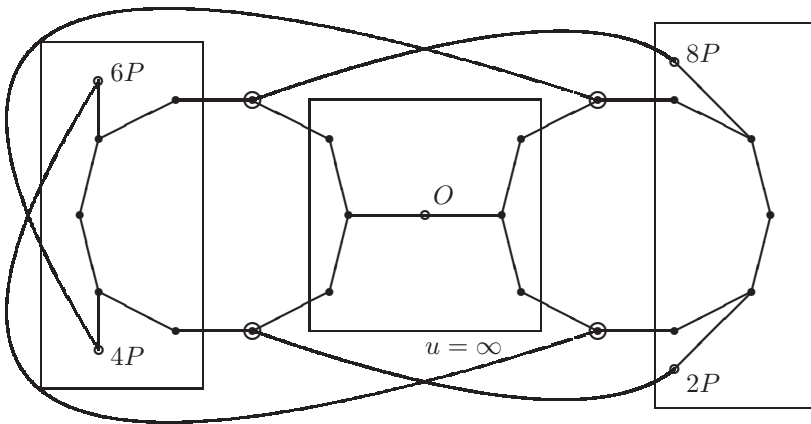

FIG. 3. Three \tilde{D}_6 divisors supported on two \tilde{A}_9 's and sections

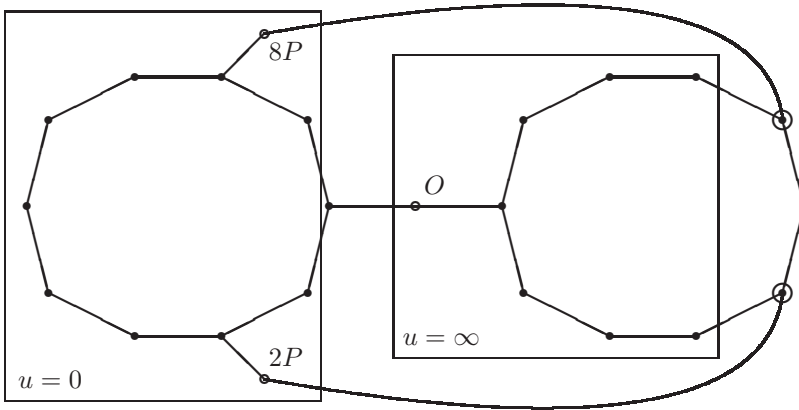

FIG. 4. \tilde{E}_7 and \tilde{D}_{10} divisors supported on two \tilde{A}_9 's and sections

model has $\rho(X/\mathbb{F}_2) = 15$: from $\rho(X/\mathbb{F}_4) = 22$, we first have to subtract 6 divisors for the two \tilde{D}_6 that are conjugate over \mathbb{F}_4 . By Tate's algorithm, the far components of the \tilde{D}_6 at $t = 1$ are also conjugate over \mathbb{F}_4 . This accounts for the seventh divisor which is not Galois invariant over \mathbb{F}_2 .

MW $\cong (\mathbb{Z}/2\mathbb{Z})^3$ with sections

$$\begin{aligned} P &= (0, 0), \\ Q &= ((t^2 + t + 1)t, (t^2 + t + 1)^2t), \\ R &= ((t + 1)(t^3 + 1), (t^3 + 1)^2), \end{aligned}$$

and their images under the automorphism $(x, y, t) \mapsto (\varrho x, y, \varrho^2 t)$.

Connection with #2. $u = x/(t^3 + 1)$ extracts two \tilde{D}_4 's from identity components of \tilde{D}_6 's and \tilde{A}_1 at ∞ plus zero section (at $u = \infty$) or from the section P and the fiber components outside $t = \infty$ meeting it (at $u = 0$). As new sections, we derive some double fiber components as depicted in the figure. Note that one of them is indeed defined over \mathbb{F}_2 .

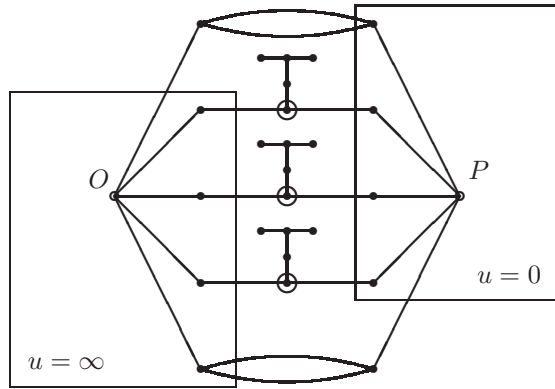

FIG. 5. Two \tilde{D}_4 fibers supported on three \tilde{D}_6 's, two \tilde{A}_1 's and two sections

In order to connect with #9, we exhibit another model of this fibration that admits the maximal Picard number $\rho(X/\mathbb{F}_2) = 21$. The coordinate change

$$(8) \quad (x, y, t) \mapsto (\varrho^2 x / (t + 1 + \varrho^2)^2, y / (t + 1 + \varrho^2)^3, \varrho(t + 1 + \varrho) / (t + 1 + \varrho^2))$$

yields the quasi-elliptic fibration $[0, 0, 0, t^2(t + 1)^2(t^2 + t + 1), 0]$. One easily verifies that the \tilde{D}_6 fibers have all components defined over \mathbb{F}_2 , so $\rho(X/\mathbb{F}_2) = 21$.

Connection with #9. $u = x / ((t^2 + t + 1)t)$ extracts \tilde{D}_4 from zero section and identity components of \tilde{A}_1 's and \tilde{D}_6 's at 0 and ∞ . There are two disjoint copies of \tilde{D}_8 . One involves most of the \tilde{D}_6 at $t = 1$ as in the figure; the other connects the two \tilde{D}_6 at 0 and ∞ by the section Q . In the new coordinates of (8), this section reads $Q = (t(t^2 + t + 1), t^2(t^2 + t + 1))$.

As new torsion sections, we identify the two fiber components depicted in the figure, and the two old sections $((t + 1)(t^2 + t + 1), (t + 1)^2(t^2 + t + 1))$ and $(t(t + 1)(t^2 + t + 1), t^2(t + 1)^2(t^2 + t + 1))$.

8.6. #6: $R(M) = D_7A_{11}$. Elliptic fibration given by $[1, t^3, t^3, 0, 0]$ with \tilde{A}_{11} at $t = 0$ and \tilde{D}_7 at ∞ . It arises as cubic base change from the rational elliptic surface with $s = t^3$.

MW = $\mathbb{Z}/4\mathbb{Z} \times A_2[2/3]$. Torsion generated by $(0, 0)$; minimal sections $(t^3 + \varrho t^2, \varrho^2 t^4)$ for $\varrho^3 = 1$ and their negatives.

Over \mathbb{Q} arithmetic and geometry of this fibration have been studied in detail in [22]. In particular, the connection to #8 has been worked out over \mathbb{Q} , and a divisor of type \tilde{D}_{20} as in #18 has been identified over \mathbb{F}_4 , albeit without expressing its linear system in terms of the above Weierstrass form.

8.7. #7: $R(M) = A_3E_6A_{11}$. Model for instance $[1, 0, t^4, 0, 0]$. Singular fibers \tilde{A}_{11} at $t = 0$, \tilde{A}_3 at $t = 1$ and \tilde{E}_6 at ∞ . MW = $\mathbb{Z}/6\mathbb{Z}$, generated by $P = (t^2, t^2)$. 3-torsion: $4P = (0, 0)$, 2-torsion: $3P = (t^4, t^6)$.

Connection with #4. $u = (y - x) / (t(x - t^2))$ extracts two divisors of type \tilde{A}_9 from \tilde{A}_{11} and \tilde{E}_6 connected by zero section and 6-torsion section $5P = (t^2, t^4)$ on the

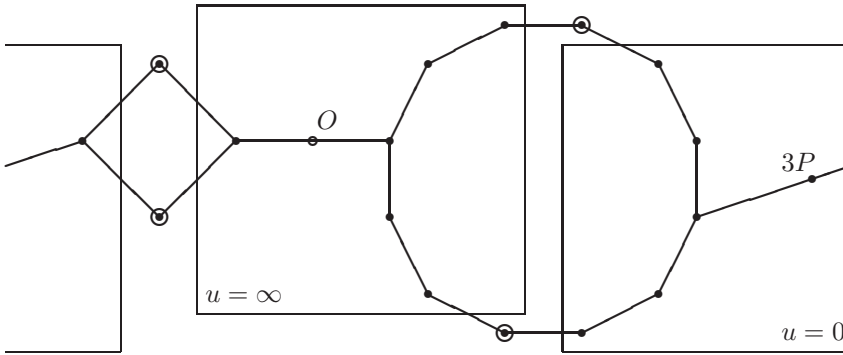

FIG. 8. Two \tilde{E}_6 divisors supported on $\tilde{A}_3, \tilde{A}_{11}$ and 2-torsion sections

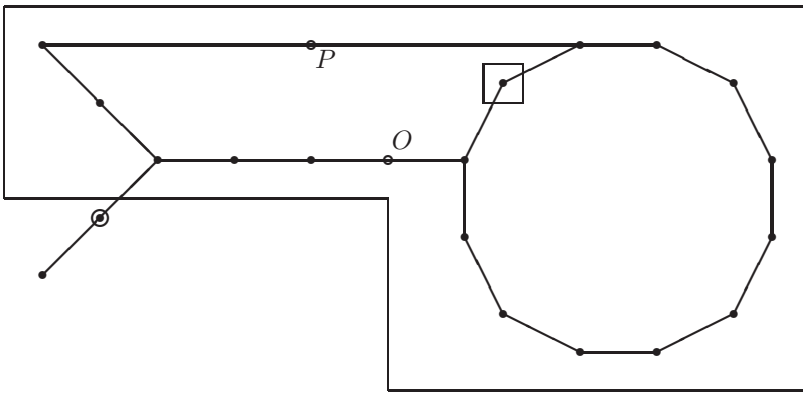

FIG. 9. \tilde{A}_{17} divisor supported on $\tilde{E}_6, \tilde{A}_{11}$ and torsion sections

Connection with #13. $u = x/t^4$ extracts two \tilde{E}_7 's first from \tilde{A}_{11} adjoined by the zero section and secondly from \tilde{E}_6 adjoined by $2P, 4P$. Remaining components of \tilde{A}_{11} combine with $3P$ and A_3 (\tilde{A}_3 minus identity component) to \tilde{D}_6 . Two sections given by fiber components as depicted.

Connection with #14. $u = (x - 1)/(t - 1)^2$ extracts \tilde{D}_8 from \tilde{E}_6 and \tilde{A}_3 connected through zero section. \tilde{D}_{12} given by A_{11} extended by sections $P, 5P$. Far components of \tilde{E}_6 serve as new sections.

8.8. #8: $R(M) = E_6^3$. Model for instance $[0, 0, t^2(t + 1)^2, 0, 0]$, as investigated in [22]. Singular fibers at $t = 0, 1, \infty$. MW = $A_2[2/3] \times \mathbb{Z}/3\mathbb{Z}$. Torsion generated by $(0, 0)$. Minimal sections $(\rho t^2, t^2)$ and their negatives.

8.9. #9: $R(M) = D_4 D_8^2$. $[0, 0, 0, t^2(t^4 + t^2 + 1), t^5(t^2 + 1)]$.
Singular fibers \tilde{D}_8 at $t = 0, \infty$, \tilde{D}_4 at $t = 1$.
MW = $(\mathbb{Z}/2\mathbb{Z})^2$ with sections $(t, 0), (t^3, 0), (t^3 + t, 0)$

8.10. #10: $R(M) = D_5 A_{15}$. $[t^2, 0, 0, 1, 0]$
Singular fibers \tilde{D}_5 at $t = 0$, \tilde{A}_{15} at ∞ .
MW = $\mathbb{Z}/4\mathbb{Z}$, generated by $P = (1, 0)$ with 2-torsion at $(0, 0)$.

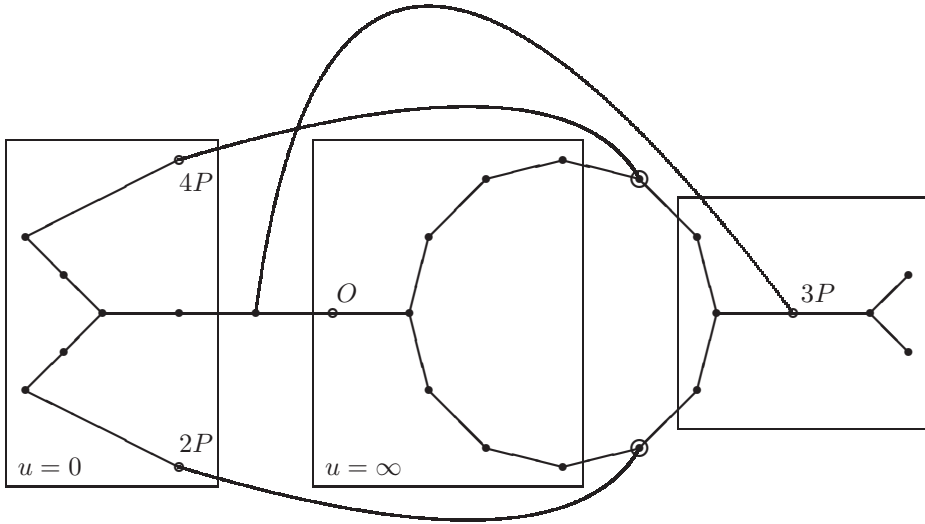

FIG. 10. Two \tilde{E}_7 and \tilde{D}_6 supported on $\tilde{E}_6, \tilde{A}_{11}, A_3$ and sections

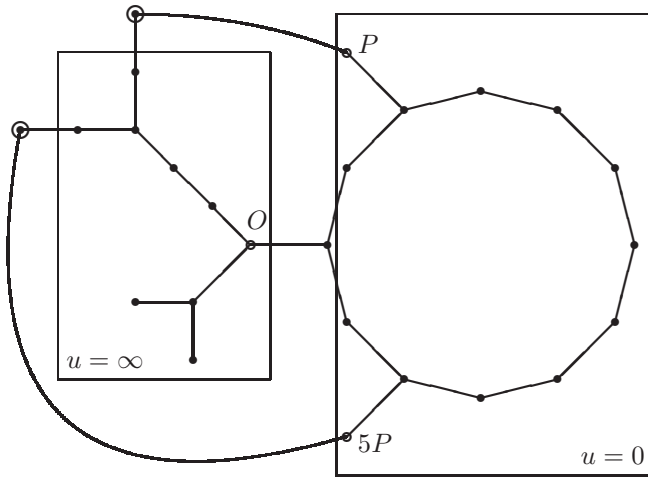

FIG. 11. \tilde{D}_8 and \tilde{D}_{12} supported on $\tilde{A}_3, \tilde{E}_6, \tilde{A}_{11}$ and sections

Connection with #6. $u = (x + t + 1)/t^2$ extracts \tilde{D}_7 from $\tilde{D}_5, \tilde{A}_{15}$ connected through zero section. The disjoint components of \tilde{A}_{15} form an A_{11} . New sections as depicted plus $P, 3P$.

8.11. #11: $R(M) = A_1^3 A_{17}$. $[t^2, 0, 1, 0, 0]$
 \tilde{A}_1 's at third roots of unity, \tilde{A}_{17} at ∞ .
 MW = $\mathbb{Z}/6\mathbb{Z}$, generated by $(t, 1)$. This fibration appears in [15, App. 2] for the peculiar fact that it admits the 2-torsion section $(1/t^2, 1/t^3)$ which is not disjoint from the zero section (this is impossible if order and characteristic are coprime).

8.12. #12: $R(M) = A_1^3 E_7 D_{10}$. quasi-elliptic $[0, 0, 0, t^2(t^3 + 1), 0]$.
 Reducible fibers: \tilde{D}_{10} at $t = 0$, \tilde{E}_7 at ∞ and \tilde{A}_1 's at third roots of unity.

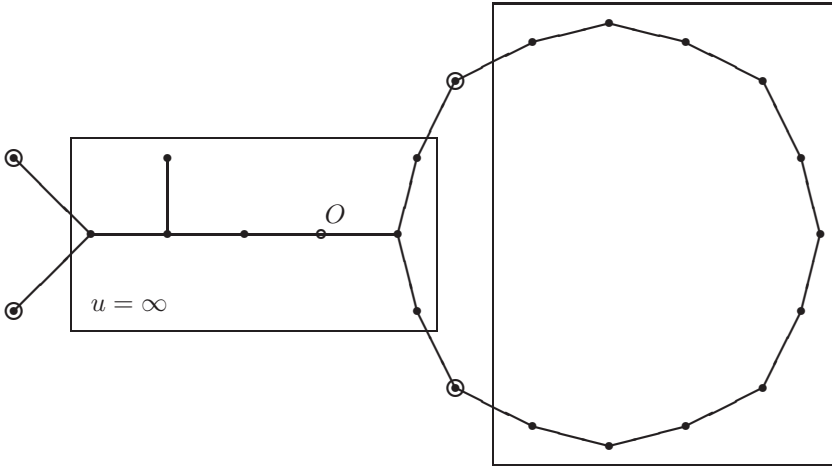

FIG. 12. \tilde{D}_7 and A_{11} supported on $\tilde{D}_5, \tilde{A}_{15}$ and zero section

MW = $(\mathbb{Z}/2\mathbb{Z})^2$ with sections $P = (0, 0), Q = (t, t^3), (t^4 + t, t^6 + t^3)$.

Connection with #15. $u = x/t^2$ extracts \tilde{D}_{16} from \tilde{E}_7 and D_{10} connected through zero section. Far component of \tilde{E}_7 combines with section P and non-identity components of \tilde{A}_1 's to form \tilde{D}_4 .

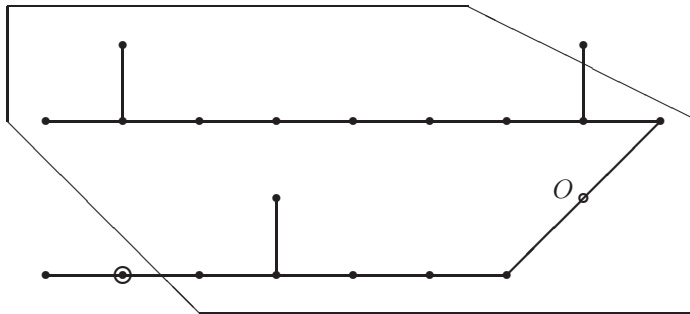

FIG. 13. \tilde{D}_{16} divisor supported on $\tilde{E}_7, \tilde{D}_{10}$ and zero section

8.13. #13: $R(M) = D_6 E_7^2$. Quasielliptic $[0, 0, 0, t^5 + t^3, 0]$
 Reducible singular fibers D_6, E_7, E_7 at $t = 1, 0, \infty$.
 MW = $\mathbb{Z}/2\mathbb{Z}$ generated by $P = (0, 0)$.

8.14. #14: $R(M) = D_8 D_{12}$. Quasielliptic $[0, t, 0, t^6, 0]$.
 Reducible fibers D_{12} at $t = 0$ and D_8 at $t = \infty$.
 MW = $\mathbb{Z}/2\mathbb{Z}$ generated by $P = (0, 0)$.

Connection with #16. $u = x/t^4$ extracts \tilde{E}_8 from \tilde{D}_{12} adjoined the zero section. D_8 then combines with P and remaining components of \tilde{D}_{12} to form a new copy of \tilde{D}_{12} .

8.15. #15: $R(M) = D_4 D_{16}$. Quasi-elliptic $[0, t^3, 0, 0, t^3]$.
 Reducible singular fibers \tilde{D}_4 at $t = 0, \tilde{D}_{16}$ at ∞ .
 MW = $\mathbb{Z}/2\mathbb{Z}$ with section $(1, 1)$.

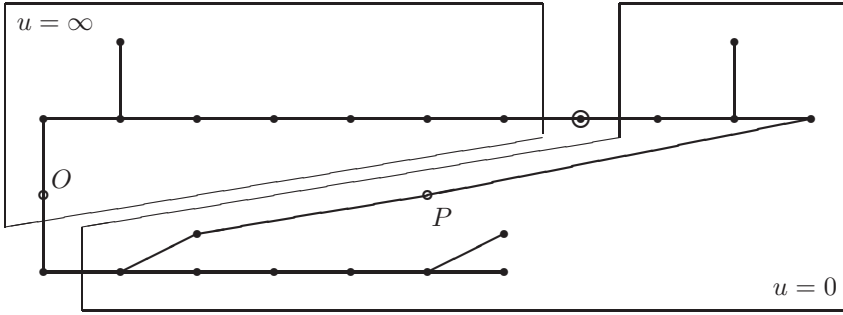

FIG. 14. \tilde{E}_8 and \tilde{D}_{12} divisors supported on $\tilde{D}_8, \tilde{D}_{12}$ and sections

8.16. #16: $R(M) = E_8 D_{12}$. quasi-elliptic $[0, t^3, 0, 0, t^5]$.
 Reducible singular fibers \tilde{E}_8 at $t = 0$, \tilde{D}_{12} at ∞ .

Connection with #18. $u = (x+t^4)/t^3$ extracts \tilde{D}_{20} from \tilde{E}_8 and \tilde{D}_{12} connected by zero section.

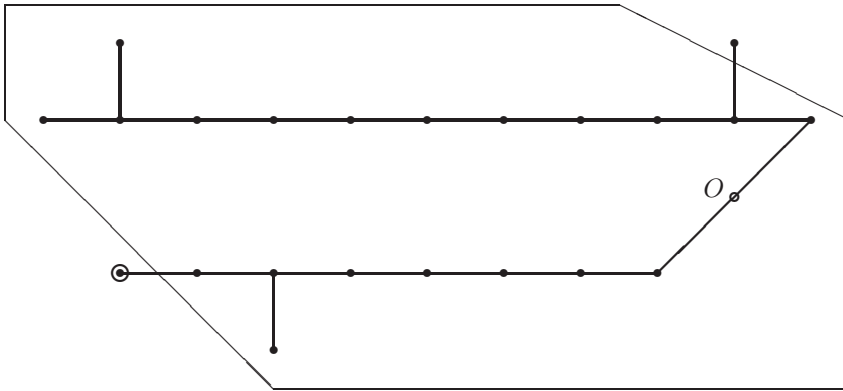

FIG. 15. \tilde{D}_{20} divisor supported on $\tilde{E}_8, \tilde{D}_{12}$ and zero section

8.17. #17: $R(M) = D_4 E_8^2$. quasi-elliptic: $[0, 0, 0, 0, t^5 + t^7]$
 Reducible fibers: \tilde{D}_4 at $t = 1$, \tilde{E}_8 at $0, \infty$. This fibration also features in [20], for instance.

Connection with #15. $u = x/t^2$ extracts \tilde{D}_{16} from the two \tilde{E}_8 's connected by the zero section. Far components of \tilde{E}_8 serve as zero and 2-torsion section. D_4 is preserved; the additional component to form a new \tilde{D}_4 consists in the curve

$$C = \{x = 0, y^2 = t^5(t + 1)^2\}.$$

which only meets the double component of \tilde{D}_4 and the far components of the two \tilde{E}_8 's.

8.18. #18: $R(M) = D_{20}$. quasi-elliptic, e.g. $[0, t^3, 0, 0, t]$ with \tilde{D}_{20} at ∞ .

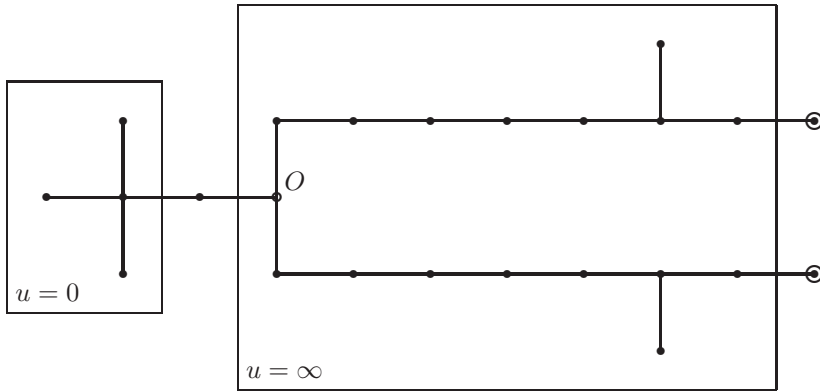

FIG. 16. \tilde{D}_{16} divisor supported on two \tilde{E}_8 's and zero section

9. Uniqueness of the genus 1 fibrations. In the previous section, we have proved that the supersingular K3 surface X admits each genus 1 fibration from Table 6.1. The proof of Theorem 1 will thus be completed by showing the uniqueness of each fibration. Here it could be possible to argue with the automorphism group of X or to pursue other lattice theoretic ideas. We decided to follow a different approach following [18] that illustrates how quasi-elliptic fibrations can be used to work out models and moduli of supersingular K3 surfaces. Namely the uniqueness problem is stated purely in terms of genus one fibrations:

PROPOSITION 9. *Let k be an algebraically closed field of characteristic two. For each genus 1 fibration from Table 6.1, there is exactly one model over k up to isomorphism.*

REMARK 10. It is a special property that the root lattice $R(L)$ determines the elliptic fibration uniquely. In comparison, on a general Kummer surface of product type the configuration of singular fibers does usually not determine a unique elliptic fibration by [14]. This is visible from the 2-torsion points, see the equations in [10].

Proof of Proposition 9 for elliptic fibrations. Suppose $S \rightarrow \mathbb{P}^1$ is an elliptic fibration from Table 6.1. If the fibration is extremal, then it is a purely inseparable base change of an extremal rational elliptic surface by [5]. The uniqueness thus follows from the corresponding statement for rational elliptic surfaces (cf. [5]). For #11, an alternative proof can be found in [24].

For the remaining three elliptic fibrations, we can still argue with extremal elliptic surfaces because there is either 3- or 4-torsion in $MW(S)$. This implies that they arise from some universal elliptic curves by base change. For 3-torsion and j -invariant zero (#8), this universal elliptic curve is

$$y^2 + sy = x^3.$$

Locating the singular fibers of type \tilde{E}_6 at $0, 1$ and ∞ , we deduce that the base change can only be $t \mapsto s = t^2(t-1)^2$. For 4-torsion, we are dealing with the universal elliptic curve

(9)
$$y^2 + xy + sy = x^3 + sx^2.$$

In any characteristic other than 2, this has three singular fibers: type I_4 at 0, I_1 at $s = 1/16$ and I_1^* at ∞ . In characteristic 2, however, the latter two are merged, but the fiber type I_1^* stays the same with wild ramification of index 1. That is, there are only two singular fibers, and each is reducible. Since fibration #6 has only two reducible fibers as well, it arises from (9) through a cyclic base change, i.e. via $t \mapsto s = t^3$. Similarly, we also deduce that #3 has no irreducible singular fibers. Locating the singular fibers at 0, 1 and ∞ , the fibration thus comes from the base change

$$t \mapsto s = t^2(t + 1)^2.$$

In particular, the elliptic fibration is unique, and we obtain the model for #3 in (5). \square

In order to complete the proof of Proposition 9, we need a few more general facts about quasi-elliptic fibrations. A good general reference is the last chapter of [3]. We have already mentioned that an elliptic curve given by a 5-tuple $[a_1, a_2, a_3, a_4, a_6]$ is quasi-elliptic in characteristic 2 if and only if $a_1 \equiv a_3 \equiv 0$. Completing the cube, we thus obtain the “traditional” Weierstrass form

$$(10) \quad S : y^2 = x^3 + a_4x + a_6.$$

Contrary to the usual situation, however, this equation still admits the following automorphisms:

$$x \mapsto x + \alpha^2, \quad y \mapsto y + \alpha x + \beta$$

in addition to rescaling x and y by a second resp. third power. Hence a_4 and a_6 are unique up to the according scaling and adding fourth powers resp. squares. Quasi-elliptic fibrations admit a discriminant that detects the reducible singular fibers:

$$\Delta = a_4(a'_4)^2 + (a'_6)^2.$$

Here the prime indicates the formal derivative with respect to the parameter of the base curve \mathbb{P}^1 . As a general rule, the order of vanishing of Δ equals the rank of the Dynkin diagram associated to (the non-identity components of) the reducible singular fiber. It suffices to distinguish two cases to normalize (10):

- (i) If Δ is a square, then so is a_4 . Thus we can set $a_6 = t\sqrt{\Delta}$ and $a_4 = \alpha^2$ where α does not contain any summand with even exponent.
- (ii) If there is a fiber of type III or III^* , then $a_6 \equiv 0$, and a_4 exactly encodes the singular fibers.

We shall now prove the uniqueness for a few quasi-elliptic fibrations from Table 6.1. We choose some cases that illustrate the overall ideas. All other fibrations can be treated along the same lines.

Proof of Proposition 9 for #13. Due to the singular fibers of type \tilde{E}_7 , we are in case (ii) above, i.e. $a_6 = 0$. Then fiber types \tilde{D}_n and \tilde{E}_7 require exact vanishing order 2 resp. 3 of a_4 . By Möbius transformation, we can thus normalize (10) uniquely as

$$S : y^2 = x^3 + t^3(t + 1)^2x.$$

The two-torsion section $(0, 0)$ implies that $\sigma = 1$ as required. \square

Proof of Proposition 9 for #9 and #17. We locate the singular fiber of type \tilde{D}_4 at $t = 1$ and the other two reducible fibers at 0 and ∞ . Then $\Delta = t^8(t - 1)^4$. The above considerations reduce the Weierstrass form (10) to

$$S : y^2 = x^3 + (ut + vt^3)^2x + t^7 + t^5.$$

Here the special fiber at $t = 0$ has type \tilde{E}_8 if $u = 0$ and \tilde{D}_8 otherwise; the analogous statement holds at $t = \infty$. We distinguish three cases. First, if $\mathbf{u} = \mathbf{v} = \mathbf{0}$, then we derive #17 in a unique way. Secondly, if $\mathbf{uv} = \mathbf{0}$ without both vanishing, then one fiber has type \tilde{E}_8 and the other \tilde{D}_8 . Note that such a surface has $\text{NS}(S) = U \oplus D_4 \oplus D_8 \oplus E_8$ and thus Artin invariant $\sigma = 2$, since the fiber type \tilde{E}_8 on a quasi-elliptic surface does not accommodate 2-torsion sections. In other words, we derive a one-dimensional family of supersingular K3 surfaces such that each member except for #17 has Artin invariant $\sigma = 2$.

Finally we consider the case $\mathbf{uv} \neq \mathbf{0}$. This yields a two-dimensional family of supersingular K3 surfaces, such that the general member has $\text{NS}(S) = U + D_4 + 2D_8$ and Artin invariant $\sigma = 3$. Here the Artin invariant drops after either specializing to the previous family or imposing some two-torsion section. The fibration #9 requires three non-trivial two-torsion sections. Their intersection behavior with the reducible fibers can be predicted from the height pairing as follows:

fiber	\tilde{D}_4	\tilde{D}_8	\tilde{E}_8
fiber	id	far	far
comp	non-id	near	far
met	non-id	far	near

We first investigate a two-torsion section $P = (X, Y)$ that fits into the first row. Here X and Y are polynomial in t of degree at most 4 resp. 6. At $t = 0$, it is immediate that $t|X, t^2|Y$. This corresponds to blowing up the surface once at the point $(x, y, t) = (0, 0, 0)$ and then along the exceptional divisor. In the affine chart $x = tx', y = t^2y''$ this yields

$$(11) \quad S : ty''^2 = x'^3 + (u + vt)^2x' + t^4 + t^2.$$

Here the near simple component of the \tilde{D}_8 fiber is given by $t = x' = 0$. The section has to follow the double component $\{t = 0, x' = u\}$ through the resolution, so $X = t(u + t \dots)$. Successively this yields $t^3|Y$ and $X = t(u + t/\sqrt{u} + t^2 \dots)$. By symmetry, the same argument applies to the fiber at ∞ . We deduce $\text{deg}(Y) \leq 3$ and $X = t^3v + t^2/\sqrt{v} + \dots$. Combining the information from $t = 0$ and $t = \infty$, we deduce $u = v$ and find a unique section $P = t(u + t/\sqrt{u} + ut^2), u^{3/2}t^3$. Again we have thus found a family of supersingular K3 surfaces with Artin invariant $\sigma \leq 2$.

We continue by imposing a torsion section $Q = (\mathcal{X}, \mathcal{Y})$ of the second kind, say meeting the fiber at ∞ at a far component. As before, this implies $\text{deg}(\mathcal{Y}) \leq 3$ and $\mathcal{X} = t^3u + t^2/\sqrt{u} + \dots$. By (11), the near component of the fiber at $t = 0$ is met if and only if $t^2|\mathcal{X}, \mathcal{Y}$, so $\mathcal{X} = t^3u + t^2/\sqrt{u}$. Finally the intersection of a non-identity component at $t = 1$ requires $(t + 1)|\mathcal{X}, \mathcal{Y}$. Hence $u = 1/\sqrt{u}$, i.e. $u^3 = 1$. The three possible choices are identified by scaling x by third roots of unity. Hence we can assume $u = 1$ and find the section $Q = (t^2(t + 1), t^2(t + 1))$. This shows that the quasi-elliptic fibrations #9 and #17 are unique. \square

For all other quasi-elliptic fibrations from Table 6.1, uniqueness can be proven along similar lines. The cases with five reducible fibers which at first sight might look most complicated are greatly simplified by the following easy observation: Any genus 1 fibration from Table 6.1 has Artin invariant $\sigma = 1$; thus it gives a model of our supersingular K3 surface X . Now X has a model with all $\text{NS}(X)$ defined over \mathbb{F}_4 . By the argumentation in Section 3, it follows that any genus 1 fibration on X admits such a model, too. For the genus 1 fibrations with five reducible fibers, this identifies

the locus of reducible fibers on the base curve as $\mathbb{P}^1(\mathbb{F}_4)$ which essentially fixes the Weierstrass form (10). Then it remains to check for precise fiber types and for fiber components to be defined over \mathbb{F}_4 .

For instance, for #2 this means that we can work with a Weierstrass form

$$S : y^2 = x^3 + \alpha t^2 x + (t^3 + 1)^3 \quad (\alpha \in \mathbb{F}_4).$$

Here the components of the fiber at $t = 1$ are encoded in the roots of the polynomial $T^3 + \alpha T + 1$. It is easily checked that this polynomial splits over \mathbb{F}_4 if and only if $\alpha = 0$. We derive the model for #2 in 8.2 with Mordell-Weil group as specified. The details for the remaining cases are left to the reader.

10. Points and lines in $\mathbb{P}^2(\mathbb{F}_4)$. Consider the elliptic fibration #1 with $R(L) = A_5^4$ and $MW \cong \mathbb{Z}/3\mathbb{Z} \times \mathbb{Z}/6\mathbb{Z}$. There are 42 obvious (-2) curves formed by the 24 components of the singular fibers and the 18 torsion sections. It is easily verified that the configuration of these 42 rational curves is the incidence graph of the 21 points and 21 lines of $\mathbb{P}^2(\mathbb{F}_4)$ (cf. [4], [6]). This gives another way to see the large finite automorphism group $\text{PGL}_3(\mathbb{F}_4) \rtimes \mathbb{Z}/2\mathbb{Z}$ acting on X . We remark that the 42 roots of $\text{NS}(X)$ under consideration are known as the first Vinberg batch of roots for $I_{1,21}$ (which contains $\text{NS}(X)$ as even sublattice, see [2, p. 551]). Note also that fiber components and sections over \mathbb{F}_2 induce the incidence graph of $\mathbb{P}^2(\mathbb{F}_2)$, so our identification is compatible with the Galois action.

For each of the other 17 fibrations in our list, most or all of the (-2) curves from $R(L)$ and torsion sections can already be seen in the $\mathbb{P}^2(\mathbb{F}_4)$ picture. For example, for the quasi-elliptic fibration #2 with $R(L) = D_4^5$ and $MW = (\mathbb{Z}/2\mathbb{Z})^4$, fiber components and sections give 41 rational curves which correspond to all but one of the 42 vertices of the incidence graph. For a few other cases, see the discussion below.

From our classification of genus 1 fibrations on X we can extract information about specific subgraphs of the incidence graph:

THEOREM 11. *The incidence graph of points and lines in $\mathbb{P}^2(\mathbb{F}_4)$ does not contain any cycle of length 14 or $2n$ with $n \geq 10$ as an induced subgraph.*

Proof. If there were such a cycle, then we would find a corresponding effective divisor on X via the elliptic fibration #1. As explained in Section 3, this divisor would induce an elliptic fibration on X with the cycle as singular fiber of type I_{2n} (jacobian by Theorem 2). Then the classification of genus 1 fibrations on X leads to the desired contradiction. \square

REMARK 12. Alternatively one can infer $n < 11$ from the Shioda-Tate formula and $n \neq 10$ from [21], but we are not aware of an easy argument ruling out $n = 7$.

PROPOSITION 13. *Let $n \in \mathbb{N}$. Assume that there are n points $P_i \in \mathbb{P}^2(\mathbb{F}_4)$ ($i \in \mathbb{Z}/n\mathbb{Z}$) such that P_i, P_{i+1}, P_j are never collinear for distinct $i, i + 1, j$. Then $n \in \{3, 4, 5, 6, 8, 9\}$. Conversely for each such n , there is a $2n$ -cycle in $\mathbb{P}^2(\mathbb{F}_4)$.*

Proof. All other cases are ruled out by Theorem 11, so the first statement of the proposition follows. As for the existence part, all $2n$ -cycles for $n < 9$ can easily be realized in the affine plane $\mathbb{A}(\mathbb{F}_4)$ by way of horizontal and vertical lines and the diagonal, say. As for the 18-cycle, one can connect, for instance, the affine points $(0, 0), (\varrho^2, 0), (\varrho, 1), (\varrho^2, 1), (\varrho, \varrho), (\varrho^2, \varrho), (\varrho, \varrho^2), (1, \varrho^2)$ and the infinite point $[0, 1, 0]$. \square

We can be even more specific by analyzing the roots perpendicular to the given $2n$ -cycle (thus forming fiber components of the induced elliptic fibration), and the

points and lines giving rise to sections. In the counts, $a + b$ indicates the partition between points and lines in $\mathbb{P}^2(\mathbb{F}_4)$.

10.1. \tilde{A}_5 . There are $9 + 9$ disjoint roots, forming another three \tilde{A}_5 hexagons, plus $9 + 9$ sections (roots that meet exactly one of the \tilde{A}_5 vertices) comprising the full MW group. Of course, this was expected since we started our current investigation exactly with this fibration.

10.2. \tilde{A}_7 . $7 + 7$ disjoint roots, forming the remaining \tilde{A}_7 and \tilde{D}_5 fibers of #3, and $8 + 8$ sections. Here MW has rank 1, so the sections can only comprise part of it.

10.3. \tilde{A}_9 . $6 + 6$ disjoint roots, forming the other \tilde{A}_9 of #4 and two isolated A_1 's; $5 + 5$ sections, accounting for the full MW group.

10.4. \tilde{A}_{11} . There are two possibilities. In one case, the vertices of the same parity on both the hexagon and its dual are always collinear. Then there are $4 + 4$ disjoint roots, forming a \tilde{D}_7 system, so we have the case of #6 with MW rank 2. There are $6 + 6$ sections. In the other case, either the hexagon or its dual is a “hyperoval”, with no three points collinear (and the other has vertices of the same parity collinear). Here there are $6 + 4$ disjoint roots, forming \tilde{E}_6 and A_3 of #7. There are $6 + 0$ sections, accounting for the full MW group. (The 0 was expected because no line meets a hyperoval in exactly one point).

10.5. \tilde{A}_{15} . Here if we look at points of the same parity on the octagon and its dual, three of the resulting four sets of 4 points are collinear and the last is in general linear position. There are $2 + 3$ disjoint roots, forming a D_5 root system, consistent with the case #10. There are $4 + 0$ sections (none for the octagon with two 4-point lines), accounting for the full MW group.

10.6. \tilde{A}_{17} . Just $1 + 1$ disjoint roots, so we see only part of the A_1^3 configuration of #11. (Happily the disjointing roots are also disjoint from each other as they must be to be part of A_1^3 .) There are $3 + 3$ sections, again fully accounting for the MW group.

\tilde{D}_n configurations. Along similar lines, we can study other configurations in the incidence graph of $\mathbb{P}^2(\mathbb{F}_4)$. The \tilde{D}_{2n} series is much like \tilde{A}_{2n-1} : instead of a polygon, we have a path whose first and last lines contain three points each rather than two – or dually where the first and last vertices have two terminal lines each instead of one. Here the lattices in our classification let us see everything up to D_{20} except D_{14} and D_{18} . Thus \tilde{D}_{14} and \tilde{D}_{18} are impossible. We will rule out \tilde{D}_{20} separately below. Conversely, for all other \tilde{D}_{2n} , $2 \leq n \leq 8$, the existence is easily derived from our analysis of \tilde{A}_{2n-1} configurations extended by sections.

EXAMPLE 14. \tilde{D}_{16} is obtained from \tilde{A}_{15} by attaching two sections (aka points in 10.5) that are not opposite while omitting the middle (-2) curve (aka line) of the shorter path connecting them in the extended \tilde{A}_{15} graph.

We shall now disprove the existence of a configuration of type \tilde{D}_{20} in $\mathbb{P}^2(\mathbb{F}_4)$. The configuration is sketched in the following figure:

The configuration includes 3 lines through P_1 , so there are 2 others which we label ℓ_1, ℓ_2 . In fact these 2 lines have to contain all points P_3, \dots, P_9 which are off the 3 lines through P_1 from the figure, but neither contains P_2 . We infer that the odd-indexed points P_3, \dots, P_9 sit on ℓ_1 and the even-indexed points P_4, \dots, P_8 on ℓ_2 . The same argument applies to P_9 and leads to a line ℓ_3 containing the even-indexed points



FIG. 17. \tilde{D}_{20} configuration in $\mathbb{P}^2(\mathbb{F}_4)$

P_2, \dots, P_6 . But then clearly $\ell_2 = \ell_3$ containing both P_2 and P_8 . This contradicts the choice of configuration which is thus impossible on $\mathbb{P}^2(\mathbb{F}_4)$.

Similarly for \tilde{D}_{2n-1} we have a path with an extra point on one side and an extra line on the other. From our classification we deduce that this is not possible past \tilde{D}_7 while we have already seen \tilde{D}_5 and \tilde{D}_7 in 10.2 and 10.4.

11. Reduction from characteristic zero. The classification of elliptic fibrations on X enables us to determine all elliptic K3 surfaces in characteristic zero with good reduction at (a prime above) 2 yielding X .

Let us explain why we consider this an interesting question. The main reason is that we have plenty of possible candidates at hand. For instance, we could work with singular K3 surfaces (attaining the maximal Picard number $\rho = 20$ over \mathbb{C}). Singular K3 surfaces always come with natural elliptic fibrations from the so-called Shioda-Inose structure. Namely there is Inose’s pencil with two II^* fibers and (in general) MW-rank two (cf. [29]). But those special fibers have wild ramification in characteristic 2 and 3 by [24], so there has to be some kind of degeneration. In fact, one can show that for any singular K3 surface the Inose pencil degenerates modulo (any prime above) 2 to the quasi-elliptic fibration #17 (so that the reduction is not smooth due to the \tilde{D}_4 fiber on the reduction). A similar pattern holds in general:

PROPOSITION 15. *Let k denote a field of characteristic zero with a fixed prime ideal above 2. Then exactly the jacobian elliptic fibrations #6 and #8 reduce smoothly to X up to isomorphism over k .*

Proof. Let $S \rightarrow \mathbb{P}^1$ be an elliptic surface over k . In order for this specific elliptic fibration to have good reduction, the singular fibers are only allowed to degenerate from multiplicative type to additive type, but never with additional fiber components (only irreducible fibers (nodal and cuspidal) and types \tilde{A}_1, \tilde{A}_2).

In the present situation, X is supersingular with $\rho(X) = 22$, but in characteristic zero $\rho(S) \leq h^{1,1}(S) = 20$. Hence in case of good reduction, the Picard number can only be increased by additional sections. In general this gives

$$\text{rank}(\text{MW}(X \rightarrow \mathbb{P}^1)) \geq \rho(X) - \rho(S) \geq 2.$$

But in the present situation, #6 and #8 are the only elliptic fibrations on X with MW rank at least two. In fact, we have equality, so any elliptic lift S must have $\rho(S) = 20$ and finite MW (i.e. it is extremal). In particular, this implies that the configurations of reducible singular fibers coincide in characteristic zero and 2. (In characteristic zero, #6 also has three singular fibers of type I_1 ; upon reduction mod 2, these singular fibers are indeed merged with the \tilde{D}_7 fiber, but the degeneration only contributes to the wild ramification [22].) Over an algebraically closed field, each configuration determines a unique elliptic surface, and the equations from #6, #8 do in fact work in any characteristic other than 3. \square

REMARK 16. Over non-algebraically closed fields (such as number fields, finite fields), there are cubic twists occurring. See [22] for an analysis over \mathbb{Q} that generalizes directly to other fields.

REMARK 17. A singular K3 surface with supersingular good reduction automatically leads to Artin invariant one by [26, Proposition 1.0.1]. Thus we infer from Proposition 15 that #6 and #8 give the only jacobian elliptic singular K3 surfaces with supersingular good reduction at a prime above 2.

Acknowledgements. We thank the referee for her or his comments. During the preparation of this manuscript, both authors enjoyed the hospitality of each other's home institution which we thank for the support. This work was started when the second author held a position at Copenhagen University.

REFERENCES

- [1] M. ARTIN, *Supersingular K3 surfaces*, Ann. scient. Éc. Norm. Sup. (4), 7 (1974), pp. 543–568.
- [2] J. CONWAY AND N. SLOANE, *Sphere Packings, Lattices and Groups*, Springer-Verlag (1988).
- [3] F. R. COSSEC AND I. V. DOLGACHEV, *Enriques surfaces, I*, Progress in Math., 76, Birkhäuser (1989).
- [4] I. DOLGACHEV AND S. KONDO, *A supersingular K3 surface in characteristic 2 and the Leech lattice*, Int. Math. Res. Not., 1 (2003), pp. 1–23.
- [5] H. ITO, *On extremal elliptic surfaces in characteristic 2 and 3*, Hiroshima Math. J., 32 (2002), pp. 179–188.
- [6] T. KATSURA AND S. KONDO, *A note on a supersingular K3 surface in characteristic 2*, Geometry and Arithmetic (Schiermonnikoog 2010), EMS Series of Congress Reports (2012), pp. 243–255.
- [7] J.-H. KEUM, *A note on elliptic K3 surfaces*, Trans. AMS, 352:5 (1999), pp. 2077–2086.
- [8] M. KNESER, *Klassenzahlen definiter quadratischer Formen*, Arch. Math., 8 (1957), pp. 241–250.
- [9] A. KUMAR, *Elliptic fibrations on a generic Jacobian Kummer surface*, J. Alg. Geom., 23 (2014), pp. 599–667.
- [10] M. KUWATA AND T. SHIODA, *Elliptic parameters and defining equations for elliptic fibrations on a Kummer surface*, in: Algebraic geometry in East Asia (Hanoi 2005), pp. 177–215, Adv. Stud. Pure Math., 50, Math. Soc. Japan, Tokyo, 2008.
- [11] H.-V. NIEMEIER, *Definite quadratische Formen der Dimension 24 und Diskriminante 1*, J. Number Theory, 5 (1973), pp. 142–178.
- [12] K.-I. NISHIYAMA, *The Jacobian fibrations on some K3 surfaces and their Mordell-Weil groups*, Japan. J. Math., 22 (1996), pp. 293–347.
- [13] K.-I. NISHIYAMA, *A remark on Jacobian fibrations on K3 surfaces*, Saitama Math. J., 15 (1997), pp. 67–71.
- [14] K. OGUIISO, *On Jacobian fibrations on the Kummer surfaces of the product of nonisogenous elliptic curves*, J. Math. Soc. Japan, 41:4 (1989), pp. 651–680.
- [15] K. OGUIISO AND T. SHIODA, *The Mordell-Weil lattice of a rational elliptic surface*, Comment. Math. Univ. St. Pauli, 40 (1991), pp. 83–99.
- [16] A. OGUS, *Supersingular K3 crystals*, Journées de Géométrie Algébrique de Rennes (Rennes 1978), Vol. II, pp. 3–86, Astérisque, 64, Soc. Math. France, Paris, 1979.
- [17] I. I. PIATETSKI-SHAPIRO AND I. R. SHAFAREVICH, *Torelli's theorem for algebraic surfaces of type K3*, Izv. Akad. Nauk SSSR Ser. Mat., 35 (1971), pp. 530–572.
- [18] A. N. RUDAKOV AND I. R. SHAFAREVICH, *Supersingular K3 surfaces over fields of characteristic 2*, Izv. Akad. Nauk SSSR, Ser. Mat., 42 (1978), pp. 848–869.
- [19] A. N. RUDAKOV AND I. R. SHAFAREVICH, *Surfaces of type K3 over fields of finite characteristic*, J. Sov. Math., 22:4 (1983), pp. 1476–1533.
- [20] S. SCHRÖER, *Kummer surfaces for the selfproduct of the cuspidal rational curve*, J. Algebraic Geom., 16 (2007), pp. 305–346.
- [21] M. SCHÜTT, *The maximal singular fibres of elliptic K3 surfaces*, Arch. Math., 87:4 (2006), pp. 309–319.
- [22] M. SCHÜTT, *Arithmetic of a singular K3 surface*, Michigan Math. J., 56 (2008), pp. 513–527.
- [23] M. SCHÜTT, *A note on the supersingular K3 surface of Artin invariant 1*, Journal of Pure and Applied Algebra, 216 (2012), pp. 1438–1441.

- [24] M. SCHÜTT AND A. SCHWEIZER, *On the uniqueness of elliptic K3 surfaces with maximal singular fibre*, Ann. Inst. Fourier, 63 (2013), pp. 689–713.
- [25] M. SCHÜTT AND T. SHIODA, *Elliptic surfaces*, Algebraic geometry in East Asia - Seoul 2008, Advanced Studies in Pure Math., 60 (2010), pp. 51–160.
- [26] I. SHIMADA, *Transcendental lattices and supersingular reduction lattices of a singular K3 surface*, Trans. AMS, 361 (2009), pp. 909–949.
- [27] T. SHIODA, *Some results on unirationality of supersingular surfaces*, Math. Ann., 230 (1977), pp. 153–168.
- [28] T. SHIODA, *On the Mordell-Weil lattices*, Comm. Math. Univ. St. Pauli, 39 (1990), pp. 211–240.
- [29] T. SHIODA, *Kummer sandwich theorem of certain elliptic K3 surfaces*, Proc. Japan Acad., 82, Ser. A (2006), pp. 137–140.

